

# INSTRUCTION MANUAL

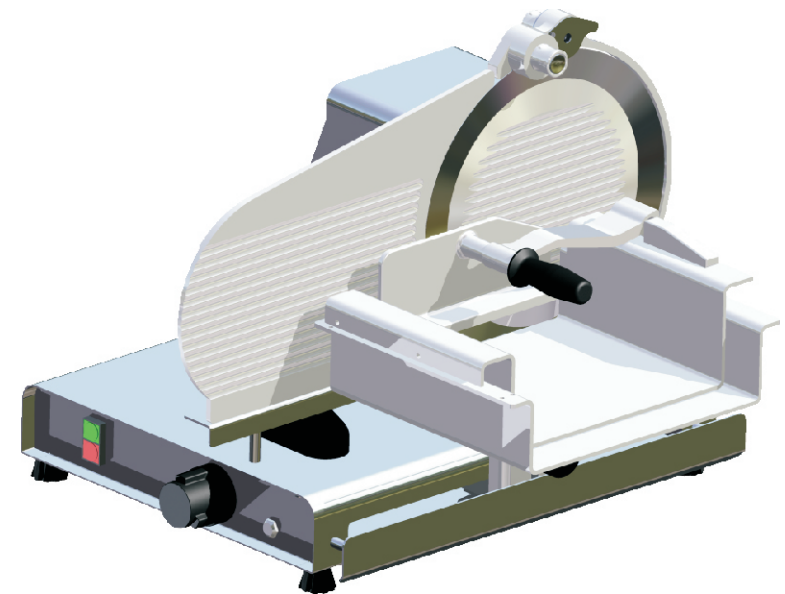

**CAUTION!**  
HAZARDOUS MOVING PARTS  
Disconnect Power Before  
Cleaning or Servicing

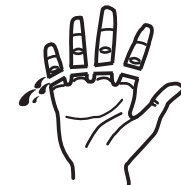

## Meat Slicer FC-350



METALÚRGICA SIEMSEN LTDA.

Rua Anita Garibaldi, nº 262 – Bairro: São Luiz – CEP: 88351-410  
Brusque – Santa Catarina – Brasil  
Fone: +55 47 3255 2000 – Fax: +55 47 3255 2020  
www.siemsen.com.br - comercial@siemsen.com.br



E-mail: at@siemsen.com.br

- ALÉM DESTAS MÁQUINAS, FABRICAMOS UMA LINHA COMPLETA DE EQUIPAMENTOS. CONSULTE SEU REVENDEDOR.  
- ESTE PRODUTO CONTA COM ASSISTÊNCIA TÉCNICA, REPRESENTANTES E REVENDEDORES EM TODO TERRITÓRIO NACIONAL.  
DEVIDO À CONSTANTE EVOLUÇÃO DOS NOSSOS PRODUTOS, AS INFORMAÇÕES AQUI CONTIDAS PODEM SER MODIFICADAS SEM AVISO PRÉVIO.

16721.5 -Julho/2009



## 9. GENERAL ADVICES

- ALWAYS turn machine off before cleaning and maintenance.
- PROVIDE enough space around machine to avoid breakings.
- ALWAYS keep the floor dry. Wet floors may cause slippings.
- ALWAYS turn machine off in case of power supply lack.
- NEVER let dust or water to get into electrical and mechanical components of the machine.
- DO NOT modify original features of the machine.
- DO NOT take out nor tear off any safety or identification label.

## 10. DIAGRAM ELECTRIC

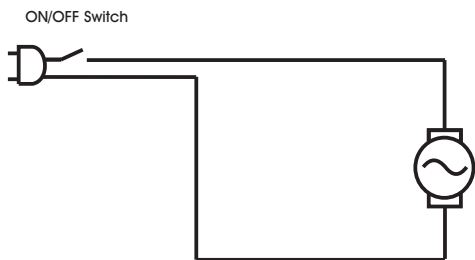

## 11. Lubrification

In case of the Complete Movable Table N° 09 (Pic.01) is jammed or hard to be moved, it is recommended the lubrication of the Movable Table Guide N° 01 (Pic.10) located on the inside part of the machine.

We suggest to use a tube or brush with silicon (liquid or paste) in order to facilitate the lubrication. Please avoid the usage of any kind of oil. Before the lubrication, it is important to remove any kind of residue that may exist on the Movable Table Guide.

01

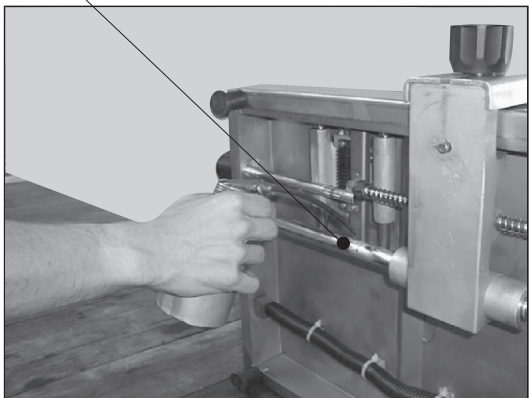

Picture - 14

## SUMMARY

1. Main Precautions .....	01
2. Main Components .....	02
3. Technical Data .....	03
4. Installation .....	03
5. Pre Operation .....	03
6. Operation .....	03
7. Sharpening .....	05
8. Cleaning .....	05
9. General Advices .....	07
10. Electric Diagram .....	07
11. Lubrication .....	07

# NOTICE TO OWNERS AND OPERATORS

The FC-350 meat slicer is designed to slice food products safely and efficiently. Unless the operator is properly trained and supervised, however, there is the possibility of a serious injury. It is the responsibility of the owner to assure that this machine is used properly and safely, strictly following the instructions contained in this Manual and any requirements of local law.

## 1. MAIN PRECAUTIONS

When incorrectly used the Meat Slicer model FC-350 can be a potentially dangerous machine. Maintenance, cleaning or any other service has to be done by trained people.

- ALWAYS turn off, unplug from power source BEFORE cleaning or servicing.
- NEVER use tools not belonging to the machine to help operation.
- NEVER touch knife edge, it could cause serious irreparable damages. Keep hands away from exposed knife.
- DO NOT catch slices with your hands, let slices drop down on receiving tray.
- DO NOT wear loose clothes mainly no loose sleeves during operation.
- NEVER connect power source with wet hands nor wet clothes.
- NEVER spray water or other liquid substances directly at motor, power switch or any other electrical components.
- ALWAYS install equipment in working area with adequate light and space away from children and visitors.
- NEVER operate without all warning labels attached and owner/operator manual available to operator.
- NEVER leave unattended while operating.
- ALWAYS ground machine properly.
- BEFORE turning machine ON check if all its removable parts are properly fitted into their right positions, and isolate machine from power supply before assembling parts.
- NEVER operate without knife guard.
- KEEP hands off the knife during operation.

		
<b>ATENÇÃO/ATENCIÓN/ATTENTION</b>		
- Antes de efectuar limpeza ou manutenção no equipamento retire o plug da rede de energia eléctrica.		
- Antes de efectuar la limpieza o mantenimiento en el equipo, sacar el enchufe de la toma de corriente eléctrica.		
- Always unplug the machine before cleaning or maintenance.		

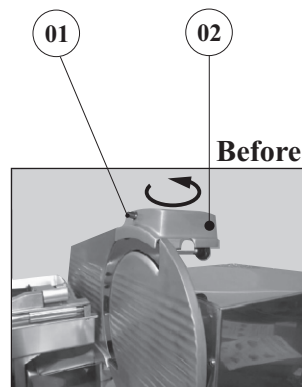

Picture - 10

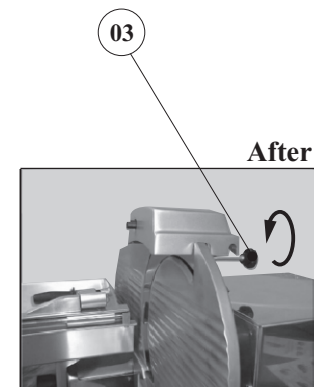

Picture - 11

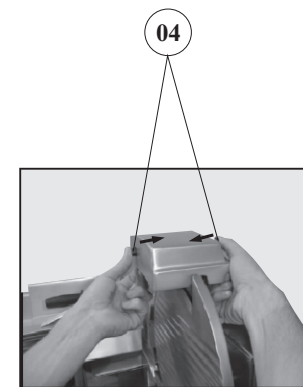

Picture - 12



Picture - 13

## 7. CLEANING

All food-contact parts must be removed and washed with warm water and neutral soap, to do that do as follows: (All pictures mentioned below are on page 04)  
Turn off slicer and disconnect electrical cord from power source.

Loosen knob No.01 (Picture-02) turning it counter-clockwise and remove cover guard No.02 (Picture-03).

**CAUTION: When removing the cover guard be careful with the knife, it can cause serious irreparable damages.**

To remove upper carriage No.02 (Picture-05) loosen knob No.01 (Picture -04) and lift up the carriage as per Picture-05. To remove lower carriage No.04 (Picture-07) loosen carriage knob No.03 (Picture-06) counter-clockwise and lift up the carriage as per Picture-07.

To remove knife sharpener No.02 (Picture-09) loosen knob No.01 (Picture-08) and lift it up. To remove plate scraper No.01 (Picture-13 on next page) just lift it up.

Wash the body of the slicer with warm water and mild soap using a soft cloth. Rinse using a clean soft cloth.

Knife cleaning: Press a damp cloth against the knife and wipe the knife slowly working outwards from the center, being careful not to let any water go into center hole where bearings are. Clean the rear side of the knife in the same way.

**NOTE: Contact your Distributor if you have any questions or problems with the installation, operation or maintenance of this machine.**

## 8. SHARPENING

**IMPORTANT: Always clean the knife before sharpening. A dirty knife will fill sharpening stones with food, making them ineffective.**

The FC-350 model is equipped with a knife sharpener. Knife sharpening is required when the cut is no longer neat. To use it correctly do as follows: (All pictures mentioned below are on next page)

- Disconnect machine from power source.

- Loosen knob No.03 (Picture-11) and lift up the sharpener No.02 (Picture-10) turning it 180° counter clockwise and placing it back on the top of the knife as per Picture-10. Then, tighten the knob No.03 (Picture-11).

- Connect machine to power source.

- Turn ON the machine and press buttons No.04 (Picture-12) of which pushes the stones right against the knife, sharpening it. Repeat this operation 3 to 5 times for 3 seconds each time, until the knife is well sharpened.

if the stones are dirty, clean them. If the stones become dull, replace them.

**IMPORTANT: After the sharpening operation move the knife sharpener back to its original position following the above procedure.**

## 2. MAIN COMPONENTS

Picture - 01

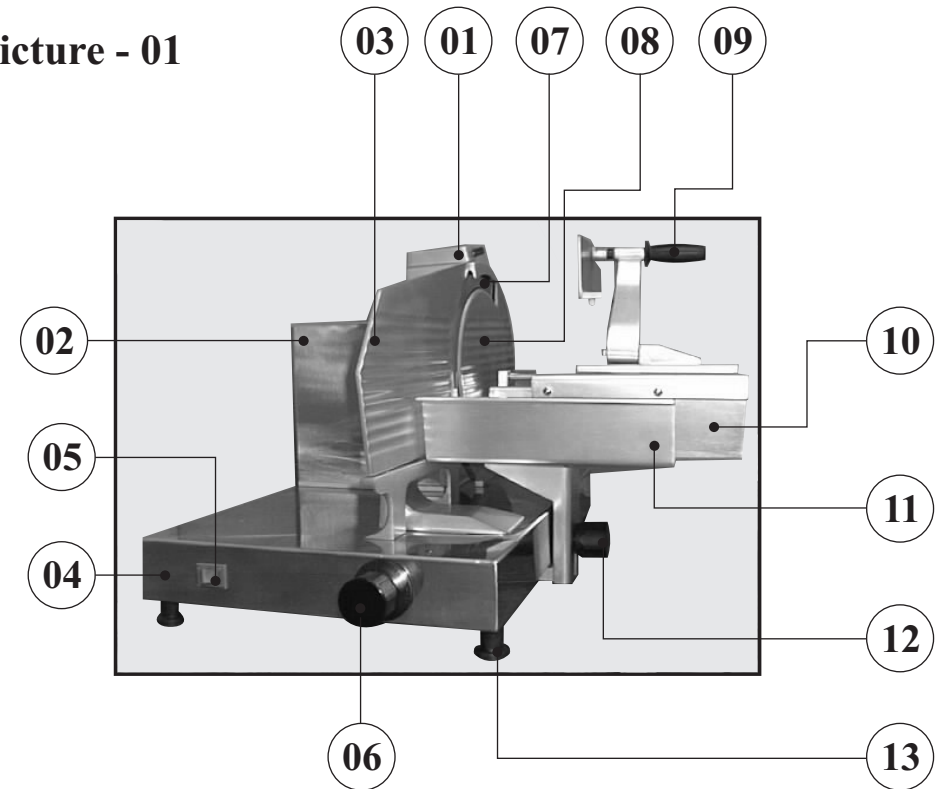

- 01 - Sharpener
- 02 - Motor Housing
- 03 - Gauge Plate
- 04 - Base
- 05 - ON/OFF Switch
- 06 - Gauge Plate Knob
- 07 - Knife 350mm (13,8 inches)
- 08 - Knife Guard
- 09 - Carriage Handle
- 10 - Upper Carriage
- 11 - Lower Carriage
- 12 - Carriage Knob
- 13 - Rubber Feet

### 3. TECHNICAL DATA

Table - 01

Technical Data	Units	FC-350
Voltage	[V]	110/220 (*)
Frequency	[Hz]	50 / 60 (*)
Horse Power	[Hp]	SEE NAMEPLATE
Consumption	[kW/h]	0,38
Height	[mm]	525
Width	[mm]	750
Lenght	[mm]	760
Net Weight /Shipping Weight	[kg]	45/49
Maximum Thickness	[mm]	40
Knife Diameter	[mm]	350
Knife Rotation	[rpm]	580

(\*) All machines are wired for the voltage and frequency as ordered.

Start machine by pressing red push-button switch No.05 (Picture-01) located on the left side of the machine. Holding firmly the carriage handle No.09 (Picture-01) move the upper carriage forward and backwards. Repeat this movement as many times as necessary.



Picture - 02

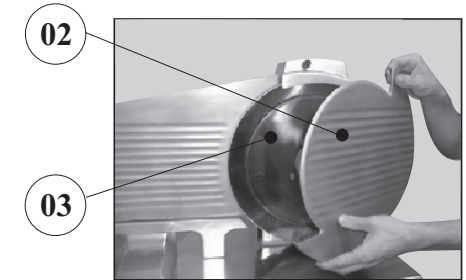

Picture - 03

### 4. INSTALLATION

The meat slicer FC-350 must be installed on a level, non-skid work surface with a maximum recommended height of 85 cm.

Check the voltage of the machine. The unit voltage must be the same as the power source voltage.

Use qualified electrician to install according to building codes.

Contact your local distributor if you have any questions or problems with the installation or operation of this machine.

This equipment is provided with a two or three pin electric cable. All pins must be connected before the machine is turned on.

### 5. PRE OPERATION

Check if machine is firm, no movement shall be allowed on the working surface. Remove and wash all food-contact parts with hot water and neutral soap. To remove the parts follow the same instructions as CLEANING.

Gauge plate is adjusted by means of knob. The only electrically-operated component of this machine is the knife. The machine is designed for continuous duty. The carriage is moved back and forth manually.

**IMPORTANT:** Make sure all removable parts are fitted properly before operation.

### 6. OPERATION

**CAUTION:** Do not use your hands to push products towards the knife, but carefully follow the procedure described hereafter.

Pull the carriage rearward to the loading position. Place boneless meat onto upper carriage No.10 (Picture-01) and press it against gauge plate No.03 (Picture-01) with the carriage handle No. 09 (Picture-01). Use gauge plate knob No.06 (Picture-01) to obtain desired thickness.

Details AA



Picture - 04

Details AA

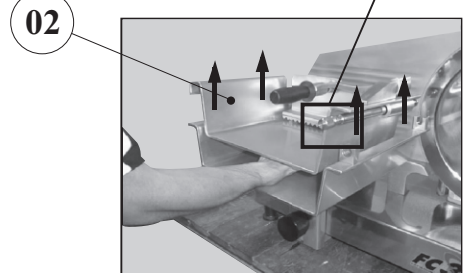

Picture - 05



Picture - 06

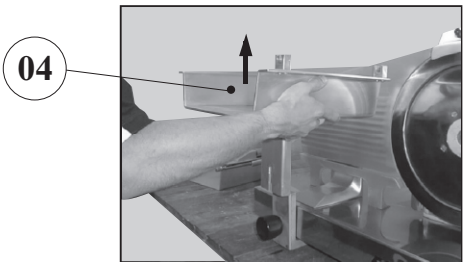

Picture - 07

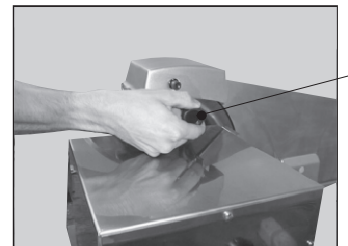

Picture - 08

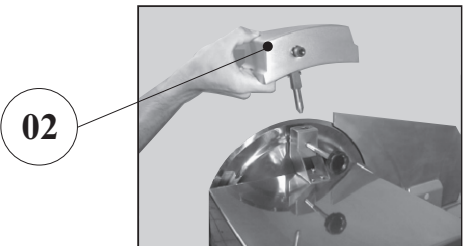

Picture - 09