



METALÚRGICA SIEMSEN LTDA.
CNPJ: 82.983.032/0001-19
Rodovia Ivo Silveira - km 12, nº 9525, Galpão 1 - Bairro: Bateas - CEP: 88355-202
Brusque - Santa Catarina - Brasil
Phone: +55 47 3211 6000 - Fax: +55 47 3211 6020
www.siemsen.com.br - comercial@siemsen.com.br

54956.8 - INGLÊS

Data de Correção: 05/11/2015

- ALÉM DESTAS Equipamentos, FABRICAMOS UMA LINHA COMPLETA DE EQUIPAMENTOS. CONSULTE SEU REVENDEDOR.
- ESTE PRODUTO CONTA COM ASSISTÊNCIA TÉCNICA, REPRESENTANTES E REVENDEDORES EM TODO TERRITÓRIO NACIONAL.
- DEVIDO À CONSTANTE EVOLUÇÃO DOS NOSSOS PRODUTOS, AS INFORMAÇÕES AQUI CONTIDAS PODEM SER MODIFICADAS SEM AVISO PRÉVIO.

WWW.SIEMSEN.COM.BR

INSTRUCTIONS MANUAL



MEAT GRINDER STAINLESS STEEL, BARREL 98

MODEL
PSP-98M

SUMMARY

1. Introduction	3
1.1 Safety	3
1.2 Main Components	5
1.3 Technical Characteristics	6
2. Installation and Pre Operation	7
2.1 Installation	7
2.2 Pre Operation	8
3. Operation	8
3.1 Starting	8
3.2 Operation Procedure	9
3.3 Grind Device Internal Assembling	10
3.4 Cleaning and Sanitizing	11
3.5 Cautions with Stainless Steel:	12
4. General Safety Practices	13
4.1 Basic Operation Procedures	13
4.2 Safety Procedures and Notes before Switching the Machine ON	14
4.3 Routine Inspection.....	14
4.4 Operation	15
4.5 After Finishing The Work.....	15
4.6 Maintenance	15
4.7 Warning.....	15
5. Analysis and Problems Solving	16
5.1 Problem, causes and solutions	16
5.2 Adjusting and Replacing Components	16
6. Maintenance	18
7. Electric Diagram	19

7. Electric Diagram

ELECTRIC NETWORK 220V / 50Hz

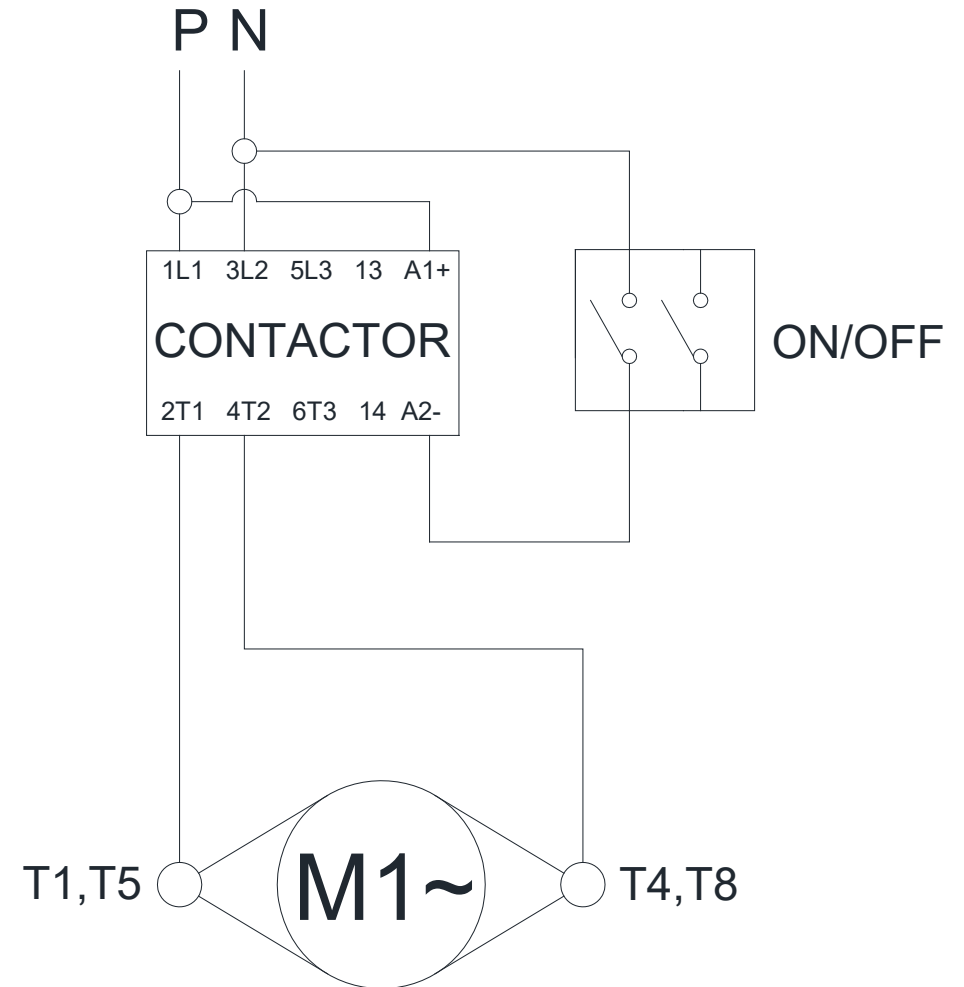

6. Maintenance

Maintenance must be considered a set of procedures with the purpose to keep the equipment best operating conditions , therefore increasing the equipment life and safety.

* Cleaning – check item 3 4 Cleaning

* Wiring - Check all wires regarding deteriorate conditions as well as all electric contacts (terminals) regarding tightening and corrosion .

*Contacts – ON/OFF switch, emergency button, reset button , electronic circuits etc , check the equipment in order to assure that all components are correctly working and the equipment operation is normal .

* Installation – make sure the installation followed item 2.1 instructions

* Equipment life span : 2 years assuming a normal day working hours

* 1 – Each month check :

- Check the electrical installation
- Measure the voltage at the socket
- Measure the working current and match it with the nominal current
- Check the tightening of all electric terminals to avoid bad contacts
- Check electric motor shaft clearance
- Check the wiring for overeating , insulation failures and mechanical damages .

2 Each three month checks

- Check electrical components such as ON/OFF switch, emergency button , reset button, electronic electric circuits , overeating, insulation failings, or mechanical damages
- Check bearings clearances
- Check retainers, O’rings, V’rings and other seals

1. Introduction

1.1 Safety

This equipment is suitable to grind meat without bones and defrosted and if not correctly used it may be potentially DANGEROUS. Maintenance, cleaning or any other service are to be done by a qualified person with the machine unplugged.

To avoid accidents, injuries and damages to the equipment, follow the below instructions :

1.1.1 Read carefully the complete instructions.

1.1.2 To avoid the risk of electric shock and damage to the equipment never use the equipment with wet clothes or wet feet, nor on a wet floor, never dip the equipment or spray water or any other liquid on it.

1.1.3 When in use the equipment must always be watched , specially when children might be near.

1.1.4 Unplug the equipment from electric network when not in use, before to clean it, before to place or remove any accessory,, during maintenance or any other kind of service.

1.1.5 Do not use any equipment having a damaged cord or plug.
Make sure the cord not to lean on a table edge, nor to touch a hot surface.

1.1.6 If the equipment has fall, is damaged or do not switch on take it to a Technical Assistance to be checked, repaired or adjusted.

1.1.7 Do not use accessories not recommended by the manufacturer.

1.1.8 Keep your hands or any tool away from the parts in movement to avoid corporal injuries or equipment damage.

1.1.9 Never use clothes with wide sleeves during operation.

1.1.10 Make sure the equipment voltage is the same as the network voltage and that the equipment is duly grounded.

1.1.11 Before to start the equipment, make sure the Barrel.# 02 (Pic 01) Is firm in its position and all its internal components are correctly assembled, see Picture 02.

1.1.12 This equipment has been developed for commercial operation, it is used for instance in restaurants, fast foods, hospitals, bakeries, butchers and similar.

It is not recommended to use it

- For continuous industrial production

- A working ambient having a corrosive or explosive atmosphere, or contaminated with water vapour, dust or gas.

IMPORTANT
Make sure the cord is in perfect working conditions , if not, change it for one in perfect conditions in accordance with the local safety norms . Such change shall be made by qualified professional.

IMPORTANT
This equipment must not be used by children or any persons with reduced physical or mental aptness, lack of experience or knowledge, unless they are under supervision or have received from the person responsible for safety, proper instructions on how to use the equipment.

IMPORTANT
Keep this equipment out of children reach

IMPORTANT
In emergency cases unplug the equipment

IMPORTANT
Do not spray water directly on the equipment

TABLE 02

PROBLEMS	CAUSES	SOLUTIONS
The machine does not start	Electricity shortage	Check electricity supply
	Worn out or broken gears	Call Technical assistance
	Problems with the electric circuits	Call Technical assistance
Smoke or burnt smell	Problems with the electric circuits	Call Technical assistance
The machine starts but the worm does not turn or turn too slow	Worn out or broken gears	Call Technical assistance
	Problems with the motor	Call Technical assistance
The cord is damaged	Damages during transportation	Call Technical assistance
Strange noise	Damaged bearings	Call Technical Assistance
The processed meat comes out smashed	One of the internal components of the Barrel is missing or assembled incorrectly	Check the internal components assembling see Pic. 02.
	Plate or knife are blunt	See item 5.2.1
The worm stops during operation	Electricity shortage	Check if the plug is in the socket and possible electricity shortage
	Problems with the electric circuits	Call Technical Assistance
	Worn out or broken gears	Call Technical Assistance
Oil leaking through the gear box	Damaged seal	Call Technical Assistance

5. Analysis and Problems Solving

5.1 Problem, causes and solutions

The Meat Grinders were designed to operate with the need of minimum maintenance but the natural wearing caused by longer use of the equipment may occasionally cause some malfunctions.

If such problem occurs with your Meat Grinder refer to the below Table in which the most common situations are listed with recommended solutions.

5.2 Adjusting and Replacing Components

5.2.1 Plate and knife sharpening

Well-sharpened plates and knife will make machine to work with less effort and consequently all components will last longer. Therefore call your nearest technical assistant to sharpen plates and knife periodically.

5.2.2 Gear Box

The Meat Grinders have a gear box lubricated with oil.

To keep your machine in good conditions for a long time check oil level at every 5.000 hours of use. Take your machine to the nearest technical assistant to do this job.

The gear box oil capacity is 250 ml. The following oils are recommended: UNITRON 140-CASTROL or similar having a viscosity (SAE140, APIGL-4 or ANP1006).

1.2 Main Components

All components are made with carefully selected materials, in accordance with Siemens experience and standard testing procedures.

The Barrel # 02 (Pic.01) and the Worm # 03 (Pic.02) receive a superficial treatment to isolate and facilitate cleaning.

Knife and plates are made of hardened material to provide a long life cutting quality.

PICTURE 01



1 - Stumper

2 - Barrel

3 - Locking Ring

4 - Pan

5 - Motor Hopusing

6 - ON/OFF Switch

1.3 Technical Characteristics

TABLE 01

CHARACTERISTICS	UNIT	PSP-98M
Average Production	kg/h	até 450
Voltage	V	220
Frequency	Hz	50
Power Rating	CV	2
Height	mm	540
Width	mm	410
Depth	mm	830
Net Weight	kg	53,3
Gross Weight	kg	71,7

4.3.2 Precautions

Check the motor and sliding or turning parts of the machine in case of abnormal noises. Check the tension of the belts and chains and replace the set when belts or chains show signs of wearing.

When checking the tension of belts or chains DO NOT insert your fingers between belts and pulleys, nor between the chains and gears.

Check protections and safety devices to make sure they are working properly.

4.4 Operation

4.4.1 Warnings

Do not use the machine with long hair that could touch any part of the machine. This might lead to a serious accident. Tie your hair up well and/or cover it with a scarf.

Only trained or skilled personnel shall operate this machine.

Never touch turning parts with your hands or any other way ,

NEVER operate the machine without any original safety devices under perfect conditions.

4.5 After Finishing The Work

4.5.1 Precautions

Always TURN THE MACHINE OFF before cleaning by removing the plug from the socket.

Never clean the machine unless it has come to a complete stop.

Put all the components back to their functional positions before turning the machine ON again.

Check the level of liquids.

Do NOT insert your fingers in between belts and pulleys nor chains and gears.

4.6 Maintenance

4.6.1 Danger

Any maintenance with the machine in working situation is dangerous. TURN IT OFF BY PULLING THE PLUG OFF THE SOCKET DURING MAINTENANCE.

IMPORTANT
Always remove the plug from the socket in any emergency situation.

4.7 Warning

Electrical or mechanical maintenance has to be undertaken by qualified personnel.

The person in charge of maintenance has to be sure that the machine is under TOTAL SAFETY conditions when working.

4.1.3 Advices

- * In case of power shortage, immediately switch the machine off.* Use recommended or equivalent lubricants, oils or greases.
- * Avoid mechanical shocks, once they may cause damages or bad functioning.
- * Avoid water, dirt or dust contact to the mechanical and electrical components of the machine.
- * DO NOT change the standard characteristics of the machine.
- * DO NOT remove, tear off or maculate any safety or identification labels stuck on the machine. If any labels have been removed or are no longer legible, contact your nearest dealer for replacement.

4.2 Safety Procedures and Notes before Switching the Machine ON

IMPORTANT

Carefully read ALL INSTRUCTIONS of this manual before turning the machine ON. Be sure to well understand all the information contained in this manual. If you have any question contact your supervisor or your nearest Dealer.

4.2.1 Danger

An electric cable or electric wire with damaged jacket or bad insulation might cause electrical shocks as well as electrical leak. Before use, check the conditions of all wires and cables.

4.2.2 Advices

Be sure to well understand all the information contained in this manual. Every operation function or procedure has to be thoroughly clear.

Before using any commands (switch, buttons, lever), be sure it is the correct one. In case of doubt, consult this manual.

4.2.3 Precautions

The electric cable has to be compatible with the power required by the machine.

Cables touching the floor or close to the machine need to be protected against short circuits.

4.3 Routine Inspection

4.3.1 Advice

When checking the tension of the belts or chains, DO NOT insert your fingers between the belts and the pulleys and nor between the chain and the gears.

2. Installation and Pre Operation

2.1 Installation

2.1.1 Placing

The Meat Grinder must be placed onto a level and stable surface, preferably 850mm high from floor.

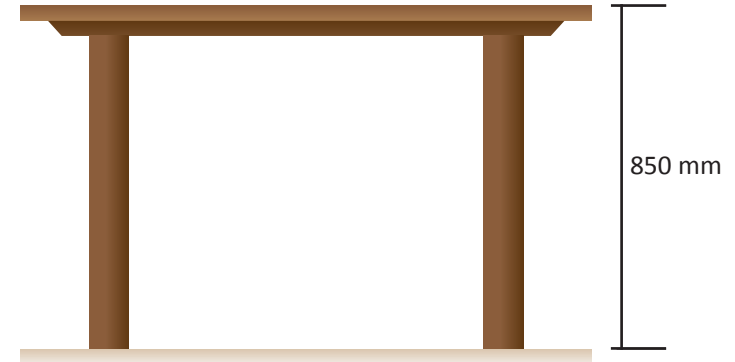

Recommended area for installation

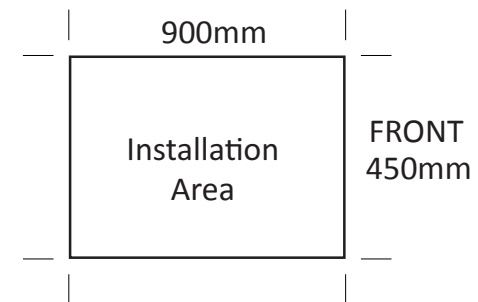

2.1.2 Electrical Installation

This equipment has been designed for 220 V., When receiving the equipment check the voltage indicated on the cord label.

The cord has a plug with three pins, the middle one is ground. It is mandatory the three pins to be duly connected before to start the machine.

IMPORTANT
Make sure the network voltage is the same as the voltage indicated on the cord label.

2.2 Pre Operation

First of all check if the machine is firm in its position.

Before operation all parts that get in contact with food must be washed with running water and neutral soap (see item 3.4 cleaning).

IMPORTANT
Do not tighten the Locking Ring too much when assembling the Grinding Device as an excessive pressure may cause to block or to break the internal components.

3. Operation

3.1 Starting

IMPORTANT
Unplug the equipment before to remove the Barrel. The machine is silent, do not let on the pan any kind of objects such as knives, forks or similar.

Make sure that the Barrel internal components follow the correct sequence as instructed on Picture 02.

Starting is made as follows:

- 1 –Plug the equipment on the network socket.
- 2- Press the ON/OFF Switch # 06 (Pic. 01) on position “I”.

4. GENERAL SAFETY PRACTICES

IMPORTANT
If any recommendation is not applicable to your equipment , please ignore it .

The following safety instructions are addressed to both the operator of the machine as well as the person in charge of maintenance.

The machine has to be delivered only in perfect conditions of use by the Distributor to the user. The user shall operate the machine only after being well acquainted with the safety procedures described in the present manual. **READ THIS MANUAL WITH ATTENTION.**

IMPORTANT
Any change in the protection systems and safety devices will during operation, create serious risks to the operator physical integrity

4.1 Basic Operation Procedures

4.1.1 Dangers

Some areas of the electric device have parts that are connected or have parts connected to high voltage. These parts when touched may cause severe electrical shocks or even be lethal.

Never touch manual commands such as switches, buttons, turning keys and knobs with your hands wearing wet clothes and/or wet shoes. By not following these instructions operator could be exposed to severe electrical shocks or even to a lethal situation.

4.1.2 Warnings

- * The operator has to be well familiar with the position of ON/OFF Switch to make sure the Switch is easy to be reached when necessary.
- * Before any kind of maintenance, physically remove plug from the socket.
- * Provide space for a comfortable operation thus avoiding accidents.
- * Water or oil spilled on the floor will turn it slippery and dangerous. Make sure the floor is clean and dry.
- * Before using any commands (switch, buttons, lever), be sure it is the correct one. In case of doubt, consult this manual.
- * Never touch any manual commands (switch, buttons, lever) unadvisedly.
- * If any work is to be made by two or more persons, coordination signs will have to be given for each operation step. Every step of the operation shall be taken only if a sign has been made and responded.

3.5 Cautions with Stainless Steel:

The Stainless Steel may present rust signs, which ARE ALWAYS CAUSED BY EXTERNAL AGENTS, especially when the cleaning or sanitization is not constant and appropriate.

The Stainless Steel resistance towards corrosion is mainly due to the presence of chrome, which in contact with oxygen allows the formation of a very thin protective coat. This protective coat is formed through the whole surface of the steel, blocking the action of external corrosive agents.

When the protective coat is broken, the corrosion process begins, being possible to avoid it by means of constant and adequate cleaning.

Cleaning must always be done immediately after using the equipment. For such end, use water, neutral soap or detergent, and clean the equipment with a soft cloth or a nylon sponge. Then rinse it with plain running water, and dry immediately with a soft cloth, this way avoiding humidity on surfaces and especially on gaps.

The rinsing and drying processes are extremely important to prevent stains and corrosion from arising.

IMPORTANT

Acid solutions, salty solutions, disinfectants and some sterilizing solutions (hypochlorites, tetravalent ammonia salts, iodine compounds, nitric acid and others), must be AVOIDED, once it cannot remain for long in contact with the stainless steel:

These substances attack the stainless steel due to the CHLORINE on its composition, causing corrosion spots (pitting).

Even detergents used in domestic cleaning must not remain in contact with the stainless steel longer than the necessary, being mandatory to remove it with plain water and then dry the surface completely.

Use of abrasives:

Sponges or steel wool and carbon steel brushes, besides scratching the surface and compromising the stainless steel protection, leave particles that rust and react contaminating the stainless steel. That is why such products must not be used for cleaning and sanitization. Scrapings made with sharp instruments or similar must also be avoided.

Main substances that cause stainless steel corrosion:

Dust, grease, acid solutions such as vinegar, fruit juices, etc., saltern solutions (brine), blood, detergents (except for the neutral ones), common steel particles, residue of sponges or common steel wool, and also other abrasives.

3.2 Operation Procedure

IMPORTANT

Under no circumstances use your hands or any other kind of instrument to push meat into the feeding throat. Use only the Stumper # 01 (Pic.01) to do this operation.

The processed meat has the function to lubricate and to cool the Barrel internal components. Therefore do not run the machine without load, as it would warm up and damage the internal components.

The Meat Grinders are relatively fast machines, therefore they need equally be fast fed.

To feed the Meat Grinders place pieces of meat on the Pan # 04 (Pic.01) and drive them with your hand towards the feeding throat entry only. Then, use the Stumper # 01 (Pic.01) to push them into the feeding throat where they will be sucked in.

3.3 Grind Device Internal Assembling

IMPORTANT

Note the correct position of each Barrel internal component. Assembling the components in a different order could cause irreparable damages to the Grinding Device.

To assemble or disassemble the Barrel internal components follow the below sequence:

PICTURE 02

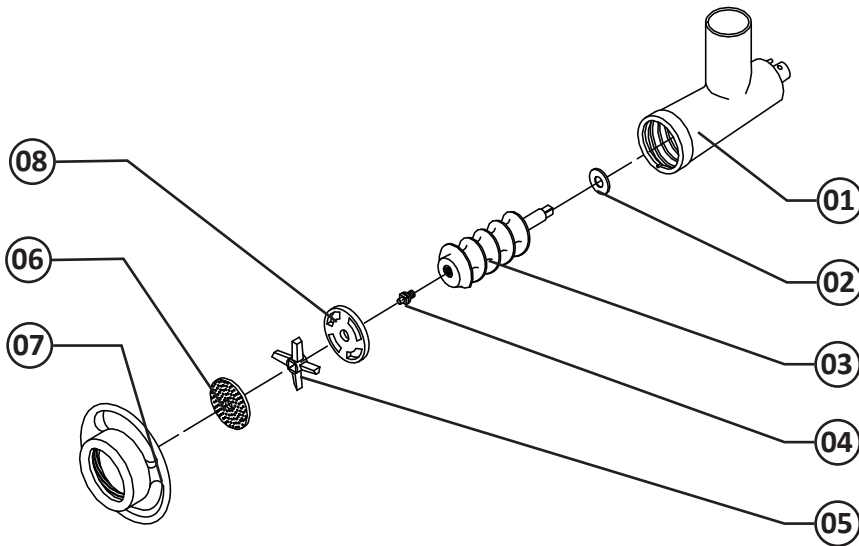

- 01- Barrel
- 02- Fiber Washer
- 03- Worm
- 04- Worm Pin

- 05- Knife
- 06- Plates 5 mm (optional 3 mm or 8 mm)
- 07- Locking Ring
- 08- Pre Cutting Plate

3.4 Cleaning and Sanitizing

IMPORTANT

Unplug the machine before to start cleaning

The equipment shall be totally cleaned and sanitized:

- Before to be used first time
- After every day's operation
- When it will not be used during a long time
- Before to operate it after a long period unused

Some parts of the equipment may be removed for cleaning, such:

- Stumper
- Pan
- Locking Ring
- Barrel and its internal components (see item 3.3)

Procedure to remove the Barrel internal components:

- Remove the Stumper # 01 (Pic.01) and the Pan # 04 (Pic.01)
- Remove the Locking Ring # 03 (Pic 01)
- Remove the Barrel # 02 (Pic.01) , hold the barrel , but before, loosen the handle on the left side of the equipment, then move the Barrel left to right and forward.
- Remove the Barrel internal components.

Wash all the parts that might be in contact with the product using water and neutral soap, then dry them with a clean cloth.

To reassemble the Barrel internal components follow item 3.3 instructions.

IMPORTANT

Do not store the Barrel with product inside, to avoid the product to freeze and therefore damage the internal components.

IMPORTANT

Do not spray water directly to the equipment