



Metalúrgica Skymesen Ltda.  
Rodovia Ivo Silveira 9525  
Volta Grande  
88355-202 Brusque/SC/Brasil  
www.skymesen.com - Fone: +55 47 3211 6000  
CNPJ: 82.983.032/0001-19 - IE 250.064.537

67496.6 - INGLÊS/ESPAÑHOL

Data de Correção: 30/09/2019

- ALÉM DESTES EQUIPAMENTOS, FABRICAMOS UMA LINHA COMPLETA DE EQUIPAMENTOS. CONSULTE SEU REVENDEDOR.  
- ESTE PRODUTO CONTA COM ASSISTÊNCIA TÉCNICA, REPRESENTANTES E REVENDEDORES EM TODO TERRITÓRIO NACIONAL.  
- DEVIDO À CONSTANTE EVOLUÇÃO DOS NOSSOS PRODUTOS, AS INFORMAÇÕES AQUI CONTIDAS PODEM SER MODIFICADAS SEM AVISO PRÉVIO.

WWW.SKYMSEN.COM

INSTRUCTION MANUAL



ONION PEELER, 6 kg

MODEL/MODELO  
**DC-06**

# SUMMARY

- 1. Introduction ..... 3**
- 1.1 Safety ..... 3
- 1.2 Main Components ..... 5
- 1.3 Technical Features ..... 6
  
- 2. Installation and Pre-Operation ..... 6**
- 2.1 Installation ..... 6
- 2.2 Pre-Operation ..... 8
  
- 3. Operation ..... 8**
- 3.1 Starting..... 8
- 3.2 Operational Procedure..... 9
- 3.3 Safety System ..... 9
- 3.4 Cleaning and Sanitizing .....10
- 3.5 Cautions with Stainless Steel .....11
  
- 4. Safety Notions ..... 12**
- 4.1 Basic Operation Procedures .....12
- 4.2 Safety Procedures and Notes before Switching the Machine ON .....13
- 4.3 Routine Inspection.....14
- 4.4 Operation .....14
- 4.5 After finishing work .....14
- 4.6 Maintenance .....15
- 4.7 Warning.....15
  
- 5. Analysis and Problems Solving..... 16**
- 5.1 Problems, Causes and solutions. ....16
  
- 6. Observed norms ..... 18**
- 7. Maintenance ..... 18**
- 8. Eletric Diagram ..... 20**

---

---

---

---

---

---

---

---

---

---

---

---

---

---

---

---

---

---

---

---

---

---

---

---

---

---

---

---

---

---

---





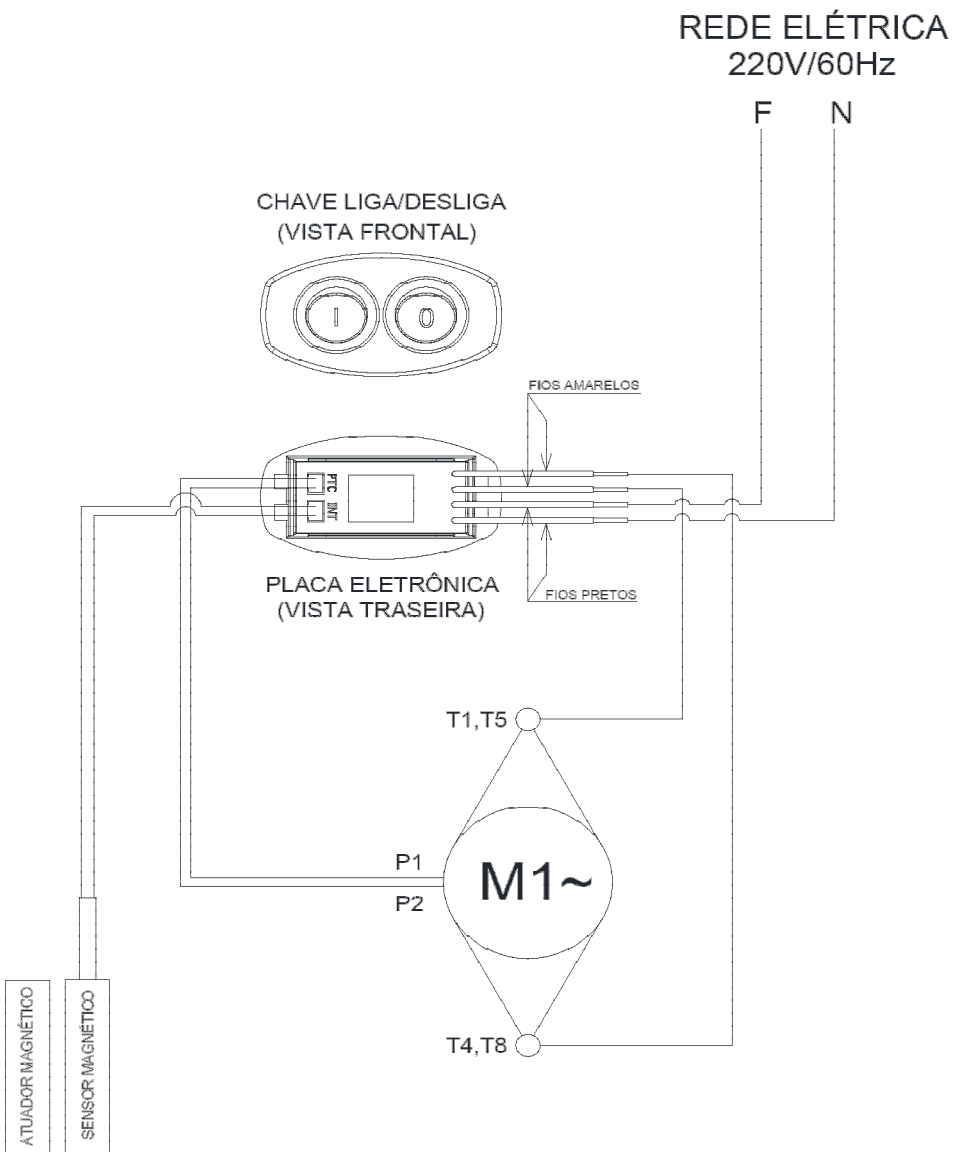

## 1.2 Main Components

All components are made with carefully selected materials, in accordance with Skymesen experience and standard testing procedures.

PICTURE 01



01 – Protection Lid  
02 – Motor Housing  
03 – Outlet Tube  
04 – Feet

05 – Cable  
06 – ON Switch  
07 – OFF Switch  
08 – Abrasive Disc

PICTURE 02

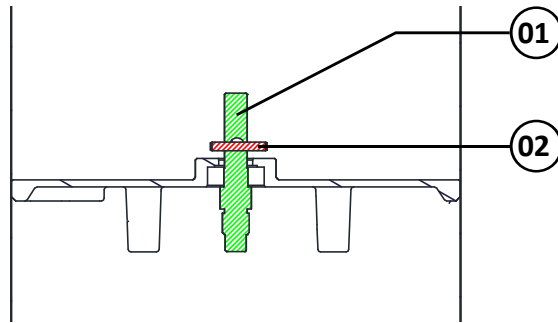

01 – Central Shaft  
02 – Central Shaft Pin

1.3 Technical Features

TABLE 01

| FEATURES           | UNIT | DC-06      |
|--------------------|------|------------|
| Average Production | kg/h | up to 120  |
| Voltage            | V    | 127 ou 220 |
| Frequency          | Hz   | 60         |
| Power              | W    | 300        |
| Height             | mm   | 570        |
| Width              | mm   | 375        |
| Depth              | mm   | 400        |
| Net Weight         | kg   | 20,5       |
| Gross Weight       | kg   | 22,5       |
| Capacity           | kg   | 06         |

2. Installation and Pre Operation

2.1 Installation

2.1.1 Placing

Place the equipment on a dry, stable and level surface.

8. Diagrama Elétrico

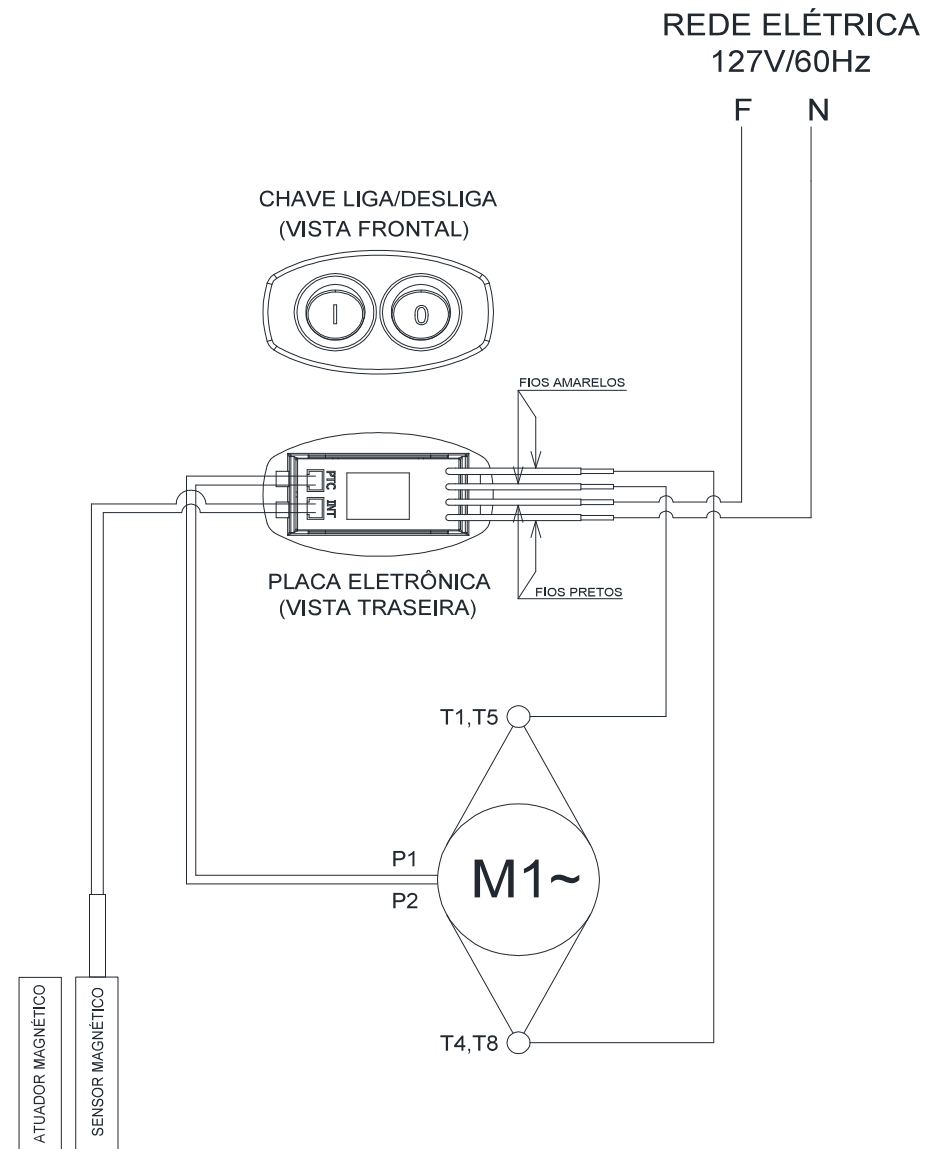

## 6. Observed Standards

Brazilian Norm NBR NM 60335-1  
IEC 60335-2-64

## 7. Maintenance

The maintenance must be a group of procedures that have the objective of keeping the appliance in its best condition of operation and increasing its life expectancy and safety.

- \* Cleaning – Check the item 3.3 Cleaning of this Manual.
- \* Electrical wiring – Check all the cables to avoid deterioration and all the electrical contacts about their tightening and corrosion.
- \* Contacts – Turn on and off Button, emergency button, reset button, electric circuits, etc. Check the appliance so that all the components are working correctly and that the operation is working normally.
- \* Installation – Check the installation of your appliance according to the item 2.1 Installation of this manual.

1 - Items to be verified and implemented monthly:

- Check the electrical installation;
- Check the outlet tension;
- Measure the operating current and compare it to the Nominal one;
- Check all the electrical terminal tightening of the appliance, to avoid bad contact;
- Check the possible clearance of the shift of the electric motor;
- Check the wiring and the electric cable to avoid its overheating, deficient isolation and mechanical breakdown.

2 - Items to be verified and implemented every 3 months:

- Check the electric components as ON/OFF Switch, Emergency Button, Reset Switch, and electric circuit related to overheating, deficient isolation and mechanical breakdown.
- Check possible loosens in the bearings
- Check retainers, o-rings, v-rings and other sealing systems.
- Check that all screws and nuts are tight to avoid possible damage to the equipment.

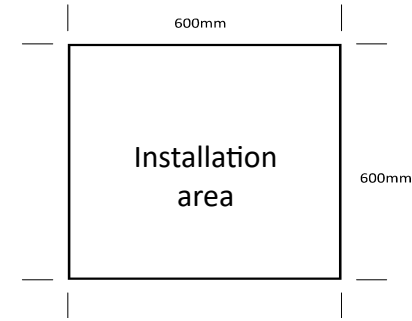

### 2.1.2 Electrical Installation

Esse equipamento foi desenvolvido para 127 ou 220 Volts (60Hz). Before plugging the equipment on the socket, make sure the network voltage is the same as indicated on the cord label.

The power plug has 3 (three) pins, the middle one is designed to grounding – Ground Pin. All the 3 (three) pins must be properly connected before operating the equipment.

**IMPORTANT**

**Make sure the network voltage is the same as indicated on the cord label.**

The figure below shows the external equipotential bonding terminal. This must be used to ensure that there is no difference in potential between different equipment connected to the electrical network, minimizing the risk of electric shocks. The different equipment must be connected to each other using their respective equipotential bonding terminals.

**PICTURE 03**



### 2.1.3 Hydraulic Installation

It is recommended to install the equipment by the water sink or canalize the water outlet extending the outlet pipe nº 10 (Pic.01). It is also necessary to install a faucet (diameter ¾) with running water directly on the product to be peeled. As a second option, the operator may capture the water in a different faucet through a hose.

**PICTURE 04**

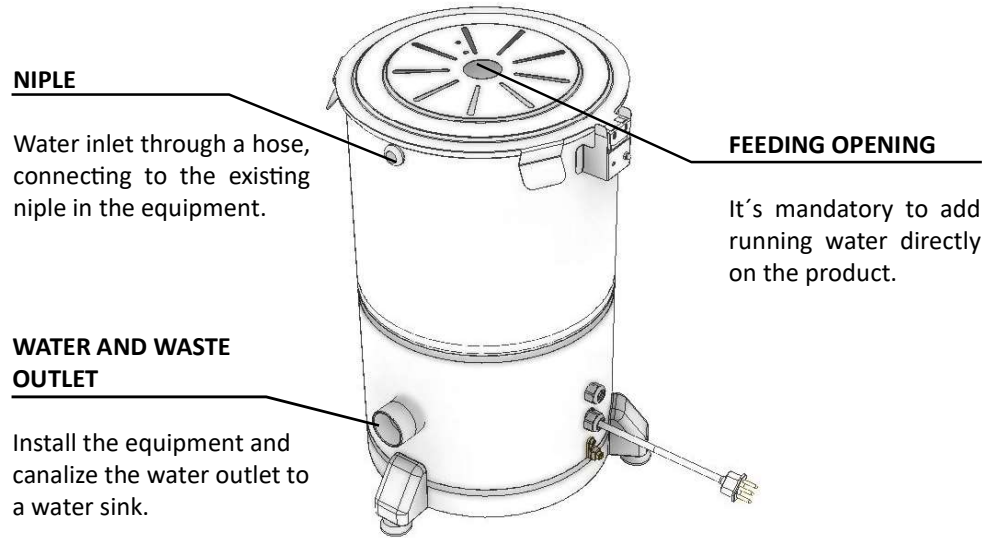

**NIPLE**  
Water inlet through a hose, connecting to the existing nipple in the equipment.

**FEEDING OPENING**  
It's mandatory to add running water directly on the product.

**WATER AND WASTE OUTLET**  
Install the equipment and canalize the water outlet to a water sink.

The water jet that enters the equipment should not exceed the center of the disc. See Picture 05.  
The water jet flow should be no more than 2,5 litres per minute.

**PICTURE 05**

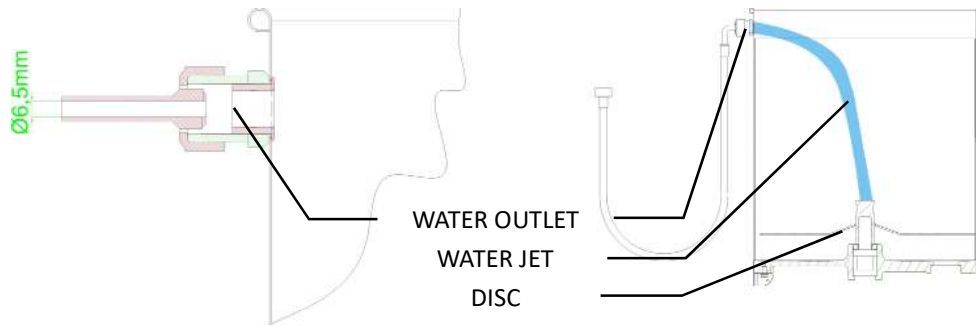

**2.2 Pre-Operation**

Before using the equipment, all the parts that are in contact with the products to be processed should be washed with water and mild detergent (see item 3.4 Cleaning).

Check if the appliance is firm in its workplace.

**3. Operation**

**3.1 Starting**

**CHART 02**

| PROBLEMS  | CAUSES   | SOLUTIONS   |
|---|--|---|
| - The machine does not start.   | - Problem with the internal or external wiring.<br>- Electric energy shortage. | - Call Technical Assistance;<br>- Check Electric Energy source. |
| - Burnt smell or smoke.   | - Problem with the internal or external wiring.                                | - Call Technical Assistance.                                    |
| - The machine starts, but when the product is placed on the Disc, the Disc stops or turns slowly. | - Belts sliding.<br>- Problem with the Electric motor.                         | - Call Technical Assistance;<br>- Call Technical Assistance.    |
| - Damaged Cord.   | - Problem during transportation.   | - Call Technical Assistance.                                    |
| - Abnormal Noises.  | - Problems with the bearings.  | - Call Technical Assistance.                                    |



## 5. Analysis and Problems Solving

### 5.1 Problem, causes and solutions

This appliance was designed to operate with the need of minimum maintenance but the natural wearing caused by longer use of the equipment may occasionally cause some malfunctions.

If any problem occurs with your equipment, the most common situations are listed below with recommended solutions.

To switch on the equipment follow the instructions below:

- Turn the equipment to the power grid.
- 1 - Check if the Lid N° 01 (Pic.: 01) is properly situated in its place.
- 2 - Press the ON Switch (N° 06 Pic. 01) to the "I" position to turn on the equipment.

### 3.2 Operation Procedure

- Put the product to be peeled inside the equipment.
- Keep the lid in its correct place.
- The equipment does not work if the Protection Lid No. 01 (Pic.01) is not fixed in its correct place.
- Let the water flow.
- Switch on the equipment using the ON Switch No. 06 (Pic.01), that is attached to the Housing side No. 02 (Pic. 01) of the equipment, positioning it in "I".
- The peeler has the maximum load of 6 kg of onion and the estimated time for the operation is 30 to 50 seconds.
- Through the opening on the Protection Lid no. 01 (Pic.01) it is possible to observe the product being peeled. After the product is peeled, switch off the equipment and remove the product manually.

### 3.4 Cleaning and Sanitizing

**IMPORTANT**  
**Always unplug the machine before cleaning process.**

The equipment must be completely clean and sanitized:

- Before being used for the first time;
- After the everyday operation;
- When it hasn't been used for a long time;
- Before using it after some time of inactivity.

- Some parts of the equipment can be removed for the cleaning:

- Abrasive Disc (Pic. 01, No. 08)

To achieve a good cleaning of the machine, follow the instructions below:

1. Switch on the equipment empty, and let it work for a few minutes, adding abundant water;
2. Switch off the equipment in the power grid and for a complete stop of the Abrasive Disc No. 08 (Pic. 01).
3. Clean the external part of the housing with a wet cloth.
4. Remove the Abrasive Disc No. 08 (Pic.01) pushing it upwards.
5. Clean the Abrasive Disc No. 08 (Pic. 01) with a nylon brush and abundant water.
6. Replace the Abrasive Disc No. 08 (Pic.01) in the equipment following the inverse procedure. Be ware for the Central Shaft Pin to fit No. 02 (Pic.02).

Wash all the parts with water and mild detergent.

**IMPORTANT**  
**Never wash the appliance with direct intense water jets.**

Any maintenance with the machine in working situation is dangerous.

SWITCH OFF THE APPLIANCE BY PULLING THE PLUG OFF THE SOCKET DURING MAINTENANCE.

**IMPORTANT**  
**Always disconnect the plug from the outlet in case of emergency.**

### 4.7 Warning

Electrical or mechanical maintenance has to be undertaken by qualified personnel.

The person in charge of maintenance has to be sure that the machine is under TOTAL SAFETY conditions when working.

### 4.2.3 Precautions

The electric cable has to be compatible with the power required by the machine.

Cables touching the floor or close to the machine need to be protected against short circuits.

The oil reservoirs have to be filled until the indicated level. Check and refill if necessary.

## 4.3 Routine Inspection

### 4.3.1 Cautions

Check the motor and the sliding and spinning parts of the appliance, in case of abnormal noise.

Check the protections and devices so that they always work properly.

## 4.4 Operation

### 4.4.1 Danger

Do not work with long hair that may touch any part of the appliance, because they may cause serious accidents. Tie them up and to the back, cover it with a scarf.

- Only trained and qualified users can operate the appliance.
- NEVER operate the appliance without any safety equipment.

## 4.5 After finishing work

### 4.5.1 Precautions

Always wash the appliance after using it.

To do that, only start cleaning it when it has come to a complete stop.

Put all components back to their functional positions before turning it on again.

## 4.6 Maintenance

### 4.6.1 Dangers

## 3.5 Cautions with Stainless Steels

The Stainless Steel may present rust signs, which ARE ALWAYS CAUSED BY EXTERNAL AGENTS, especially when the cleaning or sanitization is not constant and appropriate.

The Stainless Steel resistance towards corrosion is mainly due to the presence of chrome, which in contact with oxygen allows the formation of a very thin protective coat. This protective coat is formed through the whole surface of the steel, blocking the action of external corrosive agents.

When the protective coat is broken, the corrosion process begins, being possible to avoid it by means of constant and adequate cleaning. Cleaning must always be done immediately after using the equipment. For such end, use water, neutral soap or detergent, and clean the equipment with a soft cloth or a nylon sponge. Then rinse it with plain running water, and dry immediately with a soft cloth, this way avoiding humidity on surfaces and especially on gaps.

The rinsing and drying processes are extremely important to prevent stains and corrosion from arising.

**IMPORTANT**  
**Acid solutions, salty solutions, disinfectants and some sterilizing solutions (hypochlorites, tetravalent ammonia salts, iodine compounds, nitric acid and others), must be AVOIDED, once it cannot remain for long in contact with the stainless steel.**

These substances attack the stainless steel due to the CHLORINE on its composition, causing corrosion spots (pitting).

Even detergents used in domestic cleaning must not remain in contact with the stainless steel longer than the necessary, being mandatory to remove it with plain water and then dry the surface completely.

Use of abrasives:

Sponges or steel wool and carbon steel brushes, besides scratching the surface and compromising the stainless steel protection, leave particles that rust and react contaminating the stainless steel. That is why such products must not be used for cleaning and sanitization. Scrapings made with sharp instruments or similar must also be avoided.

Main substances that cause stainless steel corrosion:

Dust, grease, acid solutions such as vinegar, fruit juices, etc., saltern solutions (brine), blood, detergents (except for the neutral ones), common steel particles, residue of sponges or common steel wool, and also other abrasives.

## 4. Safety Notions

The following safety instructions are addressed to both the operator of the machine as well as the person in charge of maintenance.

The machine has to be delivered only in perfect conditions of use by the Distributor to the user. The user shall operate the machine only after being well acquainted with the safety procedures described in the present manual. **READ THIS MANUAL WITH ATTENTION.**

### 4.1 Basic Operation Procedures

#### 4.1.1 Dangers

Some areas of the electric device have parts that are connected or have parts connected to high voltage. These parts when touched may cause severe electrical shocks or even be lethal.

Never touch manual commands such as switches, buttons, turning keys and knobs with your hands wearing wet clothes and/or wet shoes. By not following these instructions operator could be exposed to severe electrical shocks or even to a lethal situation.

#### 4.1.2 Warnings

The operator has to be well familiar with the position of ON/OFF Switch to make sure the Switch is easy to be reached when necessary. Before any kind of maintenance, physically remove plug from the socket.

Provide space for a comfortable operation thus avoiding accidents.

Water or oil spilled on the floor will turn it slippery and dangerous. Make sure the floor is clean and dry.

Before using any commands (switch, buttons, lever), be sure it is the correct one. In case of doubt, consult this manual.

Never touch any manual commands (switch, buttons, lever) unadvisedly.

If any work is to be made by two or more persons, coordination signs will have to be given for each operation step. Every step of the operation shall be taken only if a sign has been made and responded.

#### 4.1.3 Advices

In case of power shortage, immediately switch the machine off.

- Avoid mechanical shocks, once they may cause damages or bad functioning.
- Avoid water, dirt or dust contact to the mechanical and electrical components of the machine.
- DO NOT change the original characteristics of the machine.
- DO NOT remove, tear off or maculate any safety or identification labels stuck on the machine. If any labels have been removed or are no longer legible, contact your nearest dealer for replacement.

### 4.2 Safety Procedures and Notes before Switching the Machine ON

**IMPORTANT**  
**Carefully read ALL INSTRUCTIONS of this manual before turning the machine ON.**  
**Be sure to well understand all the information contained in this manual. If you have any question contact your supervisor or your nearest Dealer.**

#### 4.2.1 Danger

An electric cable or electric wire with damaged jacket or bad insulation might cause electrical shocks as well as electrical leak. Before use, check the conditions of all wires and cables.

#### 4.2.2 Advices

Be sure to well understand all the information contained in this manual. Every operation function or procedure has to be thoroughly clear.