



YOU CAN TRUST



YOU CAN TRUST

INSTRUCTION MANUAL MANUAL DE INSTRUCCIONES

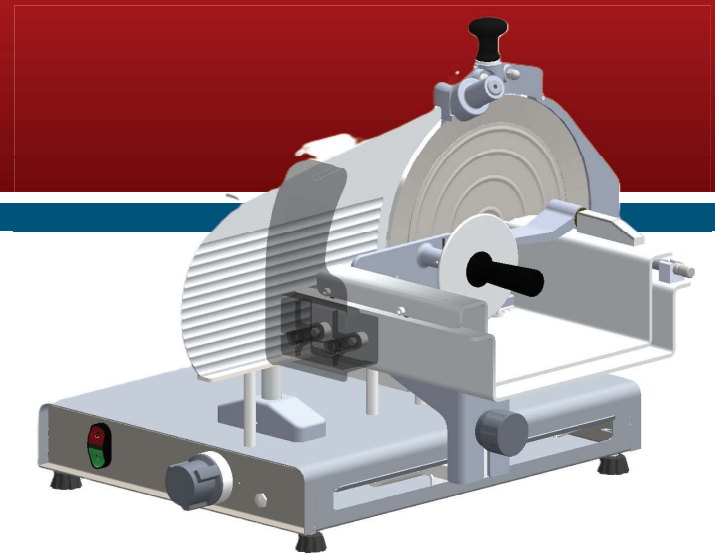

Skyfood Equipment LLC

OFFICE

175 SW 7th Street - Suite # 2416
Miami, FL 33130

1-800-503-7534 | 305-868-1603

UG0258 / 688855 - ENGLISH/ESPAÑOL

Data de Correção: 14/04/2026

CAUTION!
HAZARDOUS MOVING PARTS
Disconnect Power Before
Cleaning or Servicing



¡ATENCIÓN!
PARTES MOVIBLES PELIGROSAS
Desconecte de la Red Electrica
antes de la Limpieza o Manutención

MEAT SLICER
CORTADOR DE CARNE
FC-350

- BESIDES THIS EQUIPMENT, A COMPLETE RANGE OF OTHER PRODUCTS ARE MANUFACTURED, CONSULT OUR DEALERS
- DUE TO THE CONSTANT IMPROVEMENTS INTRODUCED TO OUR EQUIPMENTS, THE INFORMATION CONTAINED IN THE PRESENT
INSTRUCTION MANUAL MAY BE MODIFIED WITHOUT PREVIOUS NOTICE.

www.skyfood.us

KIT: 688854

SUMMARY

NOTICE TO OWNERS AND OPERATORS.....	4
1. MAIN PRECAUTIONS.....	4
2. MAIN COMPONENTS	5
3. TECHNICAL DATA.....	6
4. INSTALLATION.....	6
5. PRE OPERATION.....	6
6. OPERATION.....	7
7. CLEANING.....	8
8. SHARPENING	9
9. GENERAL ADVICES	11
10. ELECTRIC DIAGRAM	12
11. LUBRIFICATION	13

NOTICE TO OWNERS AND OPERATORS

The FC-350 meat slicer is designed to slice food products safely and efficiently. Unless the operator is properly trained and supervised, however, there is the possibility of a serious injury. It is the responsibility of the owner to assure that this machine is used properly and safely, strictly following the instructions contained in this Manual and any requirements of local law.

1. MAIN PRECAUTIONS

When incorrectly used the Meat Slicer model FC-350 can be a potentially dangerous machine. Maintenance, cleaning or any other service has to be done by trained people.

ALWAYS turn off, unplug from power source BEFORE cleaning or servicing.

NEVER use tools not belonging to the machine to help operation.

NEVER touch knife edge, it could cause serious irreparable damages. Keep hands away from exposed knife.

DO NOT catch slices with your hands, let slices drop down on receiving tray.

DO NOT wear loose clothes mainly no loose sleeves during operation.

NEVER connect power source with wet hands nor wet clothes.

NEVER spray water or other liquid substances directly at motor, power switch or any other electrical components.

ALWAYS install equipment in working area with adequate light and space away from children and visitors.

NEVER operate without all warning labels attached and owner/operator manual available to operator.

NEVER leave unattended while operating.

ALWAYS ground machine properly.

BEFORE turning machine ON check if all its removable parts are properly fitted into their right positions, and isolate machine from power supply before assembling parts.

NEVER operate without knife guard.

KEEP hands off the knife during operation.

Warranty Registration



Questions about how to complete this form?

Call 1-800-503-7534 / 305-868-1603

Return completed form to:

SKYFOOD EQUIPMENT LLC
11900 Biscayne Blvd. Suite 616
North Miami, FL 33181 - USA

Or fax form to:

786 522 6765

User Details

* Contact Person: _____

* Business type:

- | | |
|--|---|
| <input type="checkbox"/> Bakery and Bagel Operations | <input type="checkbox"/> Mass Merchandiser with Grocery |
| <input type="checkbox"/> Bakery (Associated with Restaurant) | <input type="checkbox"/> Mass Merchandiser with NO Grocery |
| <input type="checkbox"/> Bowling Center | <input type="checkbox"/> Meat Packer and Purveyor |
| <input type="checkbox"/> Business and Industry In-House Feeding | <input type="checkbox"/> Other Business that prepares or serves food |
| <input type="checkbox"/> Butcher | <input type="checkbox"/> Other Business that sells but doesn't serve food |
| <input type="checkbox"/> Catering | <input type="checkbox"/> Pizza (Dine In / Carry Out) |
| <input type="checkbox"/> Club Stores | <input type="checkbox"/> Restaurants (Independent / Chain) |
| <input type="checkbox"/> Convenience Store | <input type="checkbox"/> School |
| <input type="checkbox"/> Country Club | <input type="checkbox"/> Stadiums / Coliseum |
| <input type="checkbox"/> Delicatessen (Chain / Restaurant) | <input type="checkbox"/> Supermarket / Grocery |
| <input type="checkbox"/> Delicatessen (Independent and Non-Restaurant) | <input type="checkbox"/> Theme Park |
| <input type="checkbox"/> Food Store | <input type="checkbox"/> University / College |
| <input type="checkbox"/> Government | <input type="checkbox"/> Vineyard / Winery |
| <input type="checkbox"/> Hospital | <input type="checkbox"/> Warehouse Clubs |
| <input type="checkbox"/> Lodging | <input type="checkbox"/> Wholesale Baking Operation (Non-Institutional) |

* Company Name: _____

* Address: _____

* City: _____

* State: _____

* Zip Code: _____

* Phone: _____

Fax: _____

** E-mail: _____

Web page: _____

I would like to join the Mail List.

I would like to join the E-mail List.

Product Details

* Product Commercial Item: _____

The Product Commercial Item can be found on the machine Product Identification Label.

* Serial Number: _____

* Confirm Serial Number: _____

This information, the Product Serial Number, can also be found on the machine Product Identification Label.

* Proof of Purchase: Yes
 No

* Purchased On: _____ / _____ / _____

(mm / dd / yyyy)

* Purchased From: _____

Company Name

* Indicates required field.

** Indicates required field, not mandatory by Fax.

remedy for breach of any warranty is limited to the remedies provided in the paragraph above.

All products held at non-commercial facilities or domiciles, must be taken or shipped, shipping charges prepaid, either to SKYFOOD's facility or a SKYFOOD's designated service company ("Service Company"). Products held at commercial facilities and weighing less than seventy (70) lbs. must be taken or shipped, shipping charges are prepaid, either to SKYFOOD's facility or to a Service Company. Mileage or travel time will NOT be paid. SKYFOOD offers a limited on-site warranty for products ONLY held at commercial facilities, whose net weight exceeds seventy (70) lbs., provided they are installed in a location that is within a thirty (30) mile radius of a Service Company. **End Users are responsible for all extra travel and mileage rates.** In this case, warranty services will be provided during regular business hours.

This product will be replaced or repaired under warranty, for a period of (1) year, beginning from the date of purchase by the original purchaser/user ("End User"), or eighteen (18) months from the date of shipment from SKYFOOD's warehouse, whichever expires first.

Accessories will be replaced or repaired under warranty, for a period of (30) days, beginning from the date of purchase by the original purchaser/user ("End User"), or eighteen (18) months from the date of shipment from SKYFOOD's warehouse, whichever expires first.

This warranty shall not take effect until a properly completed and executed **WARRANTY REGISTRATION** form has been received by SKYFOOD EQUIPMENT, LLC, within thirty (30) days from the date of purchase. The **WARRANTY REGISTRATION** is available either in the Instruction Manual of every Product or at SKYFOOD's website www.skyfood.us. The End User must fill out the **WARRANTY REGISTRATION** form and send it to SKYFOOD according to the instructions posted on the referred website. **Failure to do so will VOID the warranty.**

No extended warranties for third party products. There are no other express warranties or conditions other than the one offered by each manufacturer for products sold by SKYFOOD, not under the FLEETWOOD by SKYMSSEN and SKYMSSEN brand.

For questions or assistance, do not return the product or accessories to the store, please call Toll Free 1-800-503-7534, or visit the Customer Service section at www.skyfood.us. For faster service please have the items name, serial number, and proof of purchase for the operator to assist you.

SKYFOOD reserves the right to change the terms of its limited warranty at any time without any prior notice. It also reserves the right to change the design and specifications of its equipment or any related documentation at any time. The end user is not entitled to upgrades or refunds resulting from these changes.

Updates
These **Terms and Conditions** were last updated on January 14th, 2014.



2. MAIN COMPONENTS

PICTURE 01

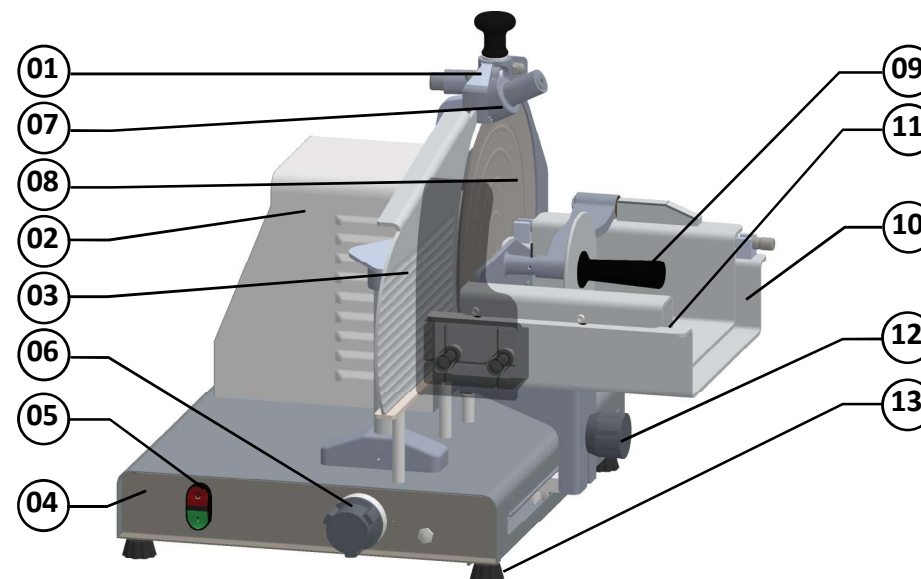

- 01 - Sharpener
- 02 - Motor Housing
- 03 - Gauge Plate
- 04 - Base
- 05 - ON/OFF Switch
- 06 - Gauge Plate Knob
- 07 - Knife 350mm (13,8 inches)

- 08 - Knife Guard
- 09 - Carriage Handle
- 10 - Upper Carriage
- 11 - Lower Carriage
- 12 - Carriage Knob
- 13 - Rubber Feet

3. TECHNICAL DATA

TABLE 01

Characteristics	Unit	FC-350
Voltage	V	110/220(*)
Electric Current	A	5,6
Frequency	Hz	50/60(*)
Power Rating	HP	See Nameplate
Consumption	Kw.h	0,38
Height	Inches	20 5/8"
Width	Inches	29 1/2"
Depth	Inches	28 2/8"
Net Weight	lb	110
Gross Weight	lb	144
Maximum Tickness	Inches	1 1/2"
Knife Diameter	inches	14"
Knife Rotation	rpm	580

(*) All machines are wired for the voltage and frequency as ordered.

4. INSTALLATION

The meat slicer FC-350 must be installed on a level, non-skid work surface with a maximum recommended height of 85 cm.

Check the voltage of the machine. The unit voltage must be the same as the power source voltage.

Use qualified electrician to install according to building codes.

Contact your local distributor if you have any questions or problems with the installation or operation of this machine.

This equipment is provided with a two or three pin electric cable. All pins must be connected before the machine is turned on.

5. PRE OPERATION

Check if machine is firm, no movement shall be allowed on the working surface. Remove and wash all food-contact parts with hot water and neutral soap. To remove the parts follow the same instructions as CLEANING.

Gauge plate is adjusted by means of knob. The only electrically-operated component of this machine is the knife. The machine is designed for continuous duty. The carriage is moved back and forth manually.

SKYFOOD EQUIPMENT LLC - SERVICE

For questions or assistance with products **FLEETWOOD** by **SKYMSEN** and **SKYMSEN**, call SKYFOOD EQUIPMENT Toll Free: **1-800-503-7534**, 24h Customer support, or visit the Customer Service section of www.skyfood.us.

SKYFOOD'S LIMITED WARRANTY

Unless otherwise specified, new **FLEETWOOD** by **SKYMSEN** and **SKYMSEN** products, excluding accessories, sold by SKYFOOD EQUIPMENT, LLC. ("SKYFOOD"), for use only in the continental United States (collectively, "Products" or singularly, "Product"), are warranted to be free from defects in materials and workmanship for a period of one (1) year from the date of purchase by the original purchaser/user ("End User"), or eighteen (18) months from the date of shipment from SKYFOOD's warehouse, whichever expires first. Several new products and accessories may be warranted for a period other than one (1) year while others may be subject to travel limitations, as specified on the products Instruction Manual. **Proof of purchase must be presented; if not this warranty will be VOID.** No warranty is given or implied to a subsequent transferee or any other third party. This warranty is expressly conditional upon SKYFOOD being notified of any defects in materials or workmanship within five (5) days of its occurrence, within the warranted time period. If a notice of a claim under this warranty is timely made by the End User, SKYFOOD or a SKYFOOD's designated service company ("Service Company"), will repair or replace the Product, at SKYFOOD's discretion, subject to the additional conditions hereinafter described.

This warranty shall not apply if damage occurs from improper installation or maintenance performed by an unauthorized service company ("Service Company"), wrong voltage, nor to the extent that Products or parts have been used other than in conformance with operating and maintenance instructions, subjected to misuse or abuse or damaged by accident, acts of God, abnormal use, stress or any other matter unrelated to SKYFOOD, and beyond its reasonable control. **This warranty does NOT cover service labor and travel to perform adjustments on products and/or accessories.** In addition to wear and tear of certain items, such as, but not limited to; glass parts, blades, stones, chopper cutting knives, plates, slicing knives, cutting disc, gaskets, oil changes, sealing tape, heat seal wires, worm gears, self-lubricating bushings, carbon brushes for electric motors, and other parts expendable by nature and that need to be replaced frequently. **Electrical components are subject to natural wear and tear, and are NOT covered by this warranty. THIS WARRANTY EXCLUDES ALL ORAL, STATUTORY, EXPRESS OR IMPLIED WARRANTIES WHICH MAY BE APPLICABLE TO SKYFOOD, INCLUDING, BUT NOT LIMITED TO, ANY IMPLIED WARRANTY OF MERCHANTABILITY AND FITNESS FOR PARTICULAR PURPOSE.** Under no circumstances shall SKYFOOD be liable for loss of use, revenue or profit or for incidental or consequential damages. SKYFOOD shall under no circumstances be liable for any loss, damage, concealed damage, expense or delay of goods for any reason when said goods are in the custody, possession or control of third parties selected by SKYFOOD to forward, enter, clear, transport, or render other services with respect to such goods. The sole and exclusive

7. DIAGRAMA ELÉCTRICO

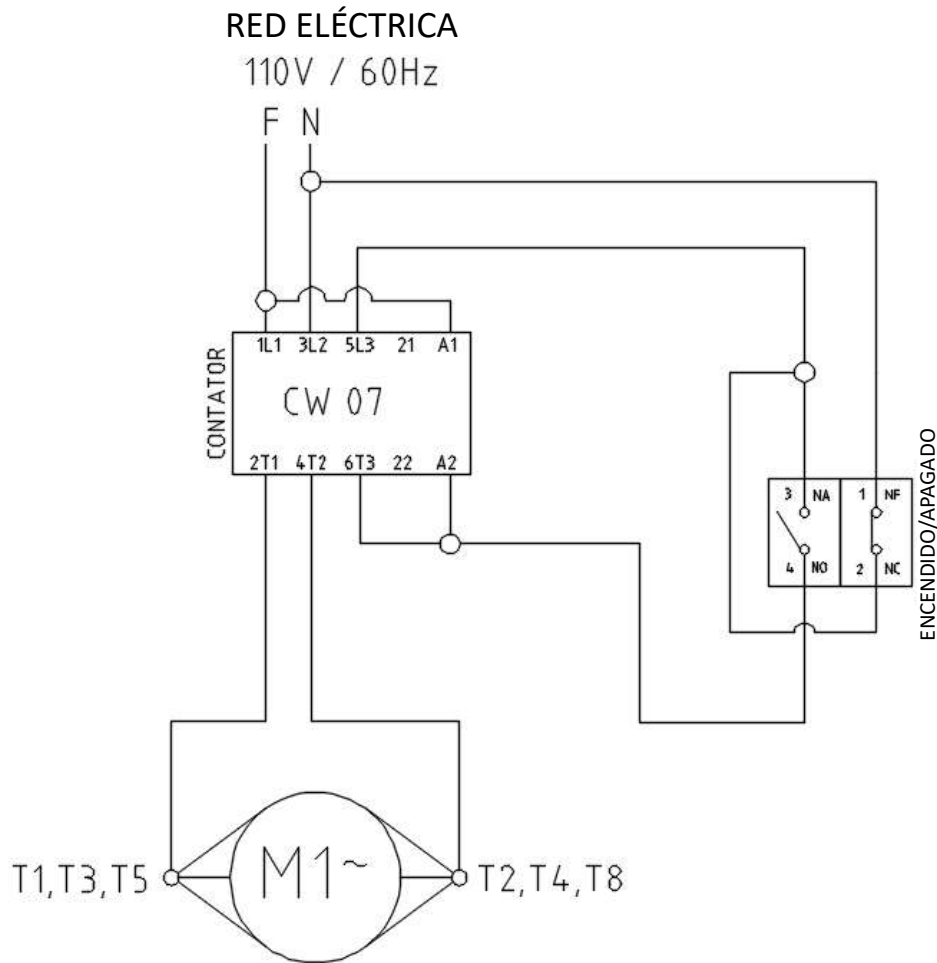

IMPORTANT

Make sure all removable parts are fitted properly before operation.

6. OPERATION

IMPORTANT

Do not use your hands to push products towards the knife, but carefully follow the procedure described hereafter.

Pull the carriage rearward to the loading position.

Place boneless meat onto upper carriage No.10 (Picture-01) and press it against gauge plate No.03 (Picture-01) with the carriage handle No. 09 (Picture-01).

Use gauge plate knob No.06 (Picture-01) to obtain desired thickness.

Start machine by pressing red push-button switch No.05 (Picture-01) located on the left side of the machine.

Holding firmly the carriage handle No.09 (Picture-01) move the upper carriage forward and backwards.

Repeat this movement as many times as necessary.

PICTURE 02

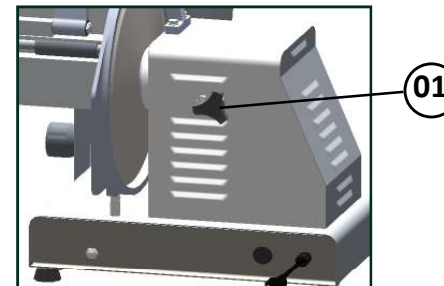

PICTURE 03

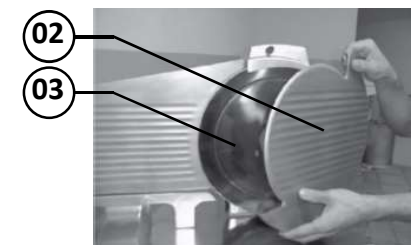

PICTURE 04 (DETAIL A)



PICTURE 05

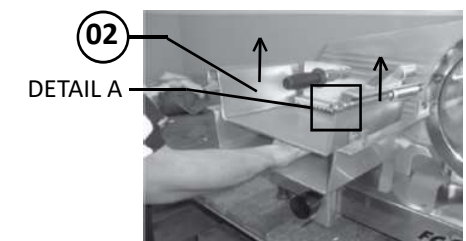

PICTURE 06

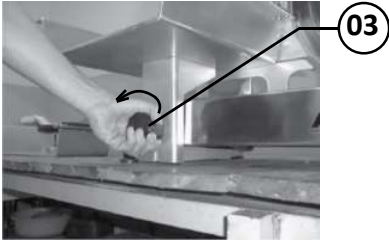

PICTURE 07

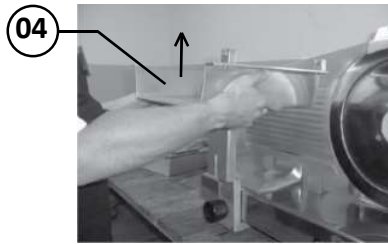

PICTURE 08

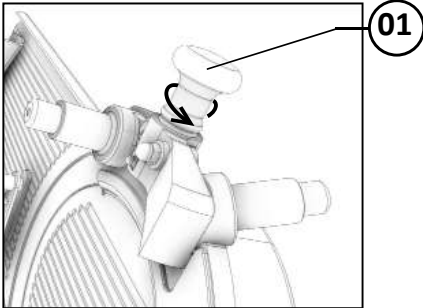

PICTURE 09

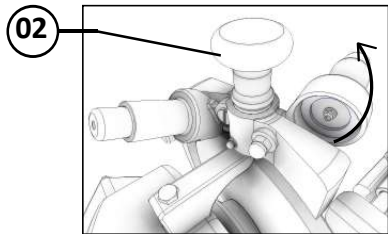

7. CLEANING

All food-contact parts must be removed and washed with warm water and neutral soap, to do that do as follows: (All pictures mentioned below are on page 04/05).

Turn off slicer and disconnect electrical cord from power source.

Loosen knob No.01 (Picture-02) turning it counter-clockwise and remove cover guard No.02 (Picture-03).

IMPORTANT
When removing the cover guard be careful with the knife, it can cause serious irreparable damages.

To remove upper carriage No.02 (Picture-05) loosen knob No.01 (Picture -04) and lift up the carriage as per Picture-05. To remove lower carriage No.04 (Picture-07) loosen carriage knob No.03 (Picture-06) counter-clockwise and lift up the carriage as per Picture-07.

To remove knife sharpener No.02 (Picture-09) loosen knob No.01 (Picture-08) and lift it up. To remove plate scraper No.01 (Picture-13 on next page) just lift it up.

Wash the body of the slicer with warm water and mild soap using a soft cloth. Rinse using a clean soft cloth.

6. CONSEJOS GENERALES

- Do not wear loose fitting clothes while operating the unit. Do not use bracelets or any other piece of jewelry. Have your hair always shortened and held up (use hair fishnets if necessary) in a way it cannot reach any part of the machine. Roll up any loose sleeves.

- SKYMSSEN is not responsible for any harm or injury caused by the negligent or inappropriate use of this equipment by any operator. This equipment must be operated only by persons whose age equals or exceeds 18 years old, in a safe and sound state of mind, free from the influence of any kind of drugs and alcohol, that received proper training and instructions regarding the correct operation of this machine, that are wearing correct and authorized safety clothes. All and any kind of modifications carried on and applied to this machine immediately nullifies any kind of warranty and may result in harm and injuries to the individuals operating this machine and to individuals that are located in the machine surrounding areas while it is being operated.

- Under no circumstances place your hands in the moving parts of the machine while it is being used. Make sure the machine has come to a complete stop before accessing the processed ingredients.

5. ANÁLISIS Y SOLUCIÓN DE PROBLEMAS

5.1 Problemas, Causas y Soluciones

La Sierra fue diseñada para que necesite un mínimo de manutención. Sin embargo, pueden ocurrir algunas irregularidades en su funcionamiento, debido al desgaste natural causado por su uso.

Caso haya algún problema con su maquina, verifique la Tabla – 02 abajo, donde están indicadas algunas soluciones recomendadas.

TABLE 02

PROBLEMAS	CAUSAS	SOLUCIONES
Olor a quemado o humo	Problema con el motor o otros circuitos eléctricos	Llame al asistente técnico autorizado
La maquina liga pero el disco demora a girar	Correas con mala tensión	Llame al asistente técnico autorizado
	Falla del condensador de partida del motor.	Llame al asistente técnico autorizado
Dificultad de corte y/o producto desmigajado	Disco sin corte o aplastado	Afile el disco, item 3.8 (pág. 22)
	Correas con mala tensión	Llame al asistente técnico autorizado
Ruidos anormales	Rodamientos con fallas	Llame al asistente técnico autorizado
El disco de corte para durante la operación	Falta de energia eléctrica	Verifique si el enchufe está en su soquete
	Correas con mala tensión	Llame al asistente técnico autorizado
	Algún contacto malo en la llave eléctrica o en otras partes eléctricas.	Llame al asistente técnico autorizado
Mesa movable con dificultad de deslizar	Falta de lubricación en la Guia de la mesa movable.	Lubrifique a guia

Knife cleaning: Press a damp cloth against the knife and wipe the knife slowly working outwards from the center, being careful not to let any water go into center hole where bearings are. Clean the rear side of the knife in the same way.

NOTE: Contact your Distributor if you have any questions or problems with the installation, operation or maintenance of this machine.

8. Sharpening the Cutting Disc

The Meat Slicer has an effective sharpening system incorporated into the equipment. This system is divided into a GROUNDING SHARPENER (item 01 fig. 10) and a FINISHING SHARPENER (item 02 fig. 10).

To sharpen the Cutting Disc, proceed as follows:

- Position the Cutting Adjustment Table in the ZERO position;

PICTURE 10

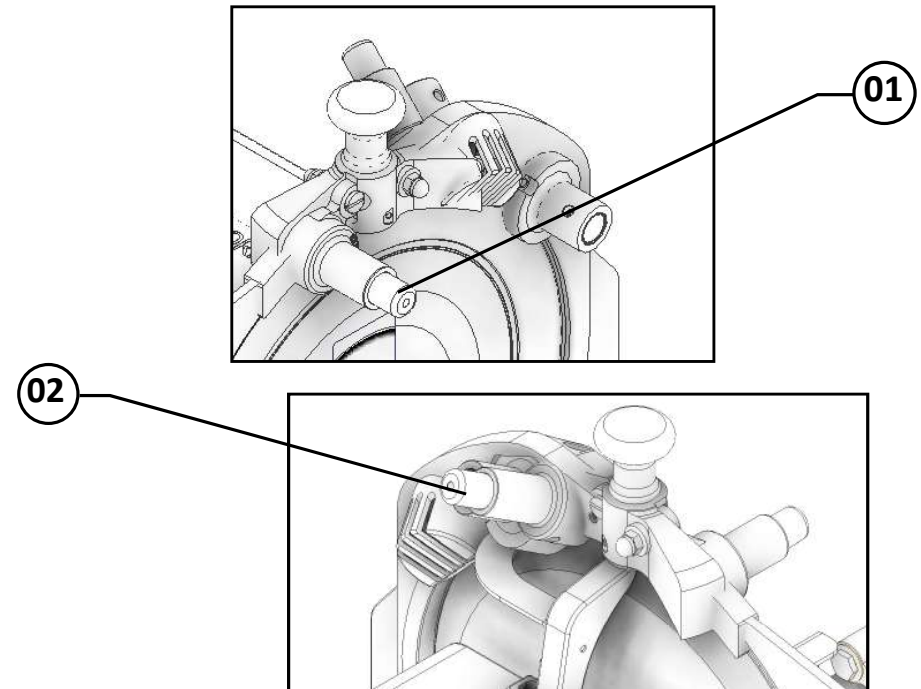

-Turn on the machine;

-First, press the GRINDING SHARPENER (item 01 fig. 10) until the abrasive wheel makes contact with the cutting edge. Keep the GRINDING SHARPENER pressed and in contact with the cutting edge for 3 seconds (repeat this operation 3 times);

-After releasing the Roughing Sharpener,

-Press the FINISHING SHARPENER (item 02 fig. 10) until the abrasive wheel makes contact with the cutting edge. Keep the FINISHING SHARPENER pressed and in contact with the cutting edge for 3 seconds (repeat this operation 3 times);

-Turn off the equipment;

-Clean the Cutting Disc.

4.7 Lubricación

Lubrique las guías deslizantes una vez por semana.



ATENCIÓN

Utilice únicamente lubricante de calidad alimentaria.

Para lubricar correctamente las guías, siga las instrucciones a continuación:

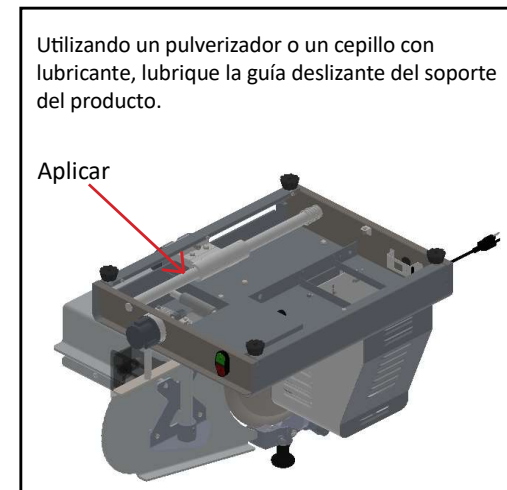
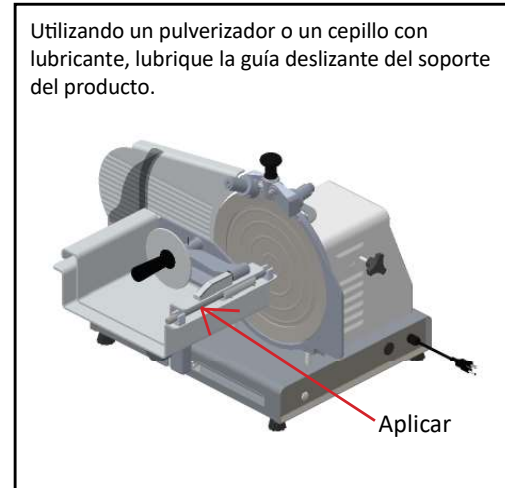

- Aplique una pequeña cantidad de aceite en las guías y mueva el conjunto de 2 a 3 veces.
- Después de lubricar, limpie el exceso de aceite.

ruidos anormales.

Verifique la tensión de las correas, y sustituya el conjunto, caso alguna correa o polea tenga desgaste. Al verificar la tensión de las correas, NO coloque los dedos entre las correas y poleas.

Verifique las protecciones y los dispositivos de seguridad para que siempre funcionen adecuadamente.

4.4 Operación

4.4.1 Avisos

No trabaje con pelo largo, que pueda tocar cualquier parte de la maquina, pues el mismo podría causar serios accidentes. Amárrelo para arriba y para atrás, o cúbralo con un pañuelo.

Solamente operadores entrenados y calificados pueden operar la maquina.

Nunca toque con las manos o de cualquier otra manera, partes girantes de la maquina.

JAMÁS opere la maquina, sin algún de sus accesorios de seguridad.

4.5 Después de Terminar el Trabajo

4.5.1 Cuidados

Siempre limpie la maquina. Para tanto, deslíguela físicamente del soquete.

Nunca limpie la maquina antes de su PARADA COMPLETA.

Recoloque todos los componentes de la maquina en sus lugares, antes de ligarla otra vez.

Al verificar la tensión de las correas/cadenas, NO coloque los dedos entre las correas y las poleas ni entre las cadenas y engranajes..

4.6 Manutención

4.6.1 Peligros

Con la maquina ligada cualquier operación de manutención es peligrosa. DESLÍGUELA FÍSICAMENTE DE LA RED ELÉCTRICA, DURANTE TODA LA OPERACIÓN DE MANUTENCIÓN.

-Verifique el apriete de todos los tornillos y tuercas para evitar posibles daños al equipo.

IMPORTANTE

Siempre desligue de la red eléctrica en cualquier caso de emergencia.

4.7 Aviso

La manutención eléctrica o mecánica debe ser hecha por una persona calificada para hacer el trabajo.

La persona encargada por la manutención debe certificarse que la maquina trabaje bajo condiciones TOTALES DE SEGURIDAD.

9. GENERAL ADVICES

ALWAYS turn machine off before cleaning and maintenance.

PROVIDE enough space around machine to avoid breakings.

ALWAYS keep the floor dry. Wet floors may cause slippings.

NEVER let dust or water to get into electrical and mechanical components of the machine.

DO NOT modify original features of the machine.

DO NOT take out nor tear off any safety or identification label.

* Service life – 2 years for regular work shift.

Do not wear loose fitting clothes while operating the unit. Do not use bracelets or any other piece of jewelry. Have your hair always shortened and held up (use hair fishnets if necessary) in a way it cannot reach any part of the machine. Roll up any loose sleeves.

SKYMSEN is not responsible for any harm or injury caused by the negligent or inappropriate use of this equipment by any operator. This equipment must be operated only by persons whose age equals or exceeds 18 years old, in a safe and sound state of mind, free from the influence of any kind of drugs and alcohol, that received proper training and instructions regarding the correct operation of this machine, that are wearing correct and authorized safety clothes.

All and any kind of modifications carried on and applied to this machine immediately nullifies any kind of warranty and may result in harm and injuries to the individuals operating this machine and to individuals that are located in the machine surrounding areas while it is being operated.

Under no circumstances place your hands in the moving parts of the machine while it is being used. Make sure the machine has come to a complete stop before accessing the processed ingredients.

10. ELECTRIC DIAGRAM

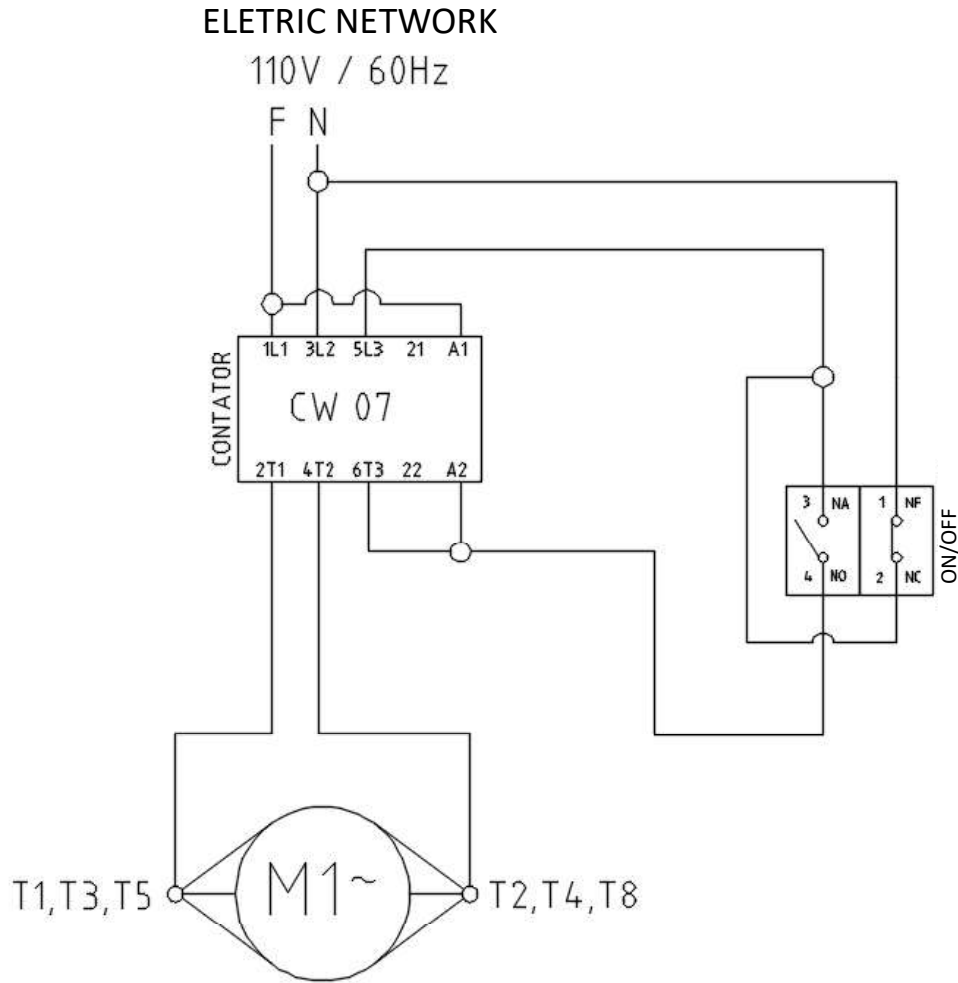

Evite choques mecánicos, ellos pueden causar fallas o malo funcionamiento.
Evite que agua, suciedad o polvo entren en los componentes mecánicos y eléctricos de la maquina.

NO ALTERE las características originales de la maquina.

NO SUCIE, RASGUE O RETIRE CUALQUIER ETIQUETA DE SEGURIDAD O DE IDENTIFICACIÓN.

Caso alguna esté ilegible o perdida, solicite otra al Asistente Técnico más cercano.

LEA ATENTAMENTE Y CON CUIDADO LAS ETIQUETAS DE SEGURIDAD Y DE IDENTIFICACIÓN CONTENIDAS EN LA MAQUINA, ASÍ COMO LAS INSTRUCCIONES Y LAS TABLAS TÉCNICAS CONTENIDAS EN ESTE MANUAL.

4.2 Cuidados y Observaciones Antes de Prender la Maquina.

IMPORTANTE

Lee con atención y cuidado las INSTRUCCIONES contenidas en este Manual, antes de ligar la maquina. Certifíquese que entendió correctamente todas las informaciones. En caso de duda, consulte su superior o el Revendedor.

4.2.1 Peligro

Cables o hilos eléctricos con aislamiento dañado, pueden provocar choques eléctricos. Antes de usarlos verifique sus condiciones.

4.2.2 Avisos

Esté seguro que las INSTRUCCIONES contenidas en este Manual, estén completamente entendidas. Cada función o procedimiento de operación y de manutención debe estar perfectamente claro.

El accionamiento de un comando manual (botón, llave eléctrica, palanca, etc.) debe ser hecho siempre después que se tenga la certitud de que es el comando correcto.

4.2.3 Cuidados

El cable de alimentación de energía eléctrica de la maquina, debe tener una sección suficiente para soportar la potencia eléctrica consumida.

Cables eléctricos que estuvieran en el suelo cerca de la maquina, deben ser protegidos para evitar corto circuitos.

4.3 Inspección de Rutina

4.3.1 Aviso

Al averiguar la tensión de las correas/cadenas, NO coloque los dedos entre las correas y las poleas, ni cadenas y engranajes.

4.3.2 Cuidados

Verifique los motores y las partes deslizantes o girantes de la maquina, con relación a

4. NOCIONES GENERALES DE SEGURIDAD

IMPORTANTE

Si cualquiera de las recomendaciones no fuera aplicable, ignórela

Las Nociones Generales de Seguridad fueran preparadas para orientar y instruir adecuadamente a los operadores de las maquinas, así como aquellos que serán responsables por su manutención.

La maquina solamente debe ser entregue al operador en buenas condiciones de uso, al que el operador debe ser orientado cuanto al uso y a la seguridad de la maquina por el Revendedor. El operador solamente debe usar la maquina con el conocimiento completo de los cuidados que deben ser tomados, después de LER ATENTAMENTE TODO ESTE MANUAL.

4.1 Practicas Básicas de Operación

4.1.1 Peligros

Algunas partes del accionamiento eléctrico presentan puntos o terminales con altos voltajes. Cuando tocados pueden ocasionar graves choques eléctricos, o hasta la muerte de una persona.

Nunca toque un comando manual (botón, llave eléctrica, etc.) con las manos, zapatos o ropas mojadas. No atender a esta recomendación, también podrá provocar choques eléctricos, o hasta la muerte de una persona.

4.1.2 Advertencias

El local de la llave liga / desliga debe ser bien conocido, para que sea posible accionarla a cualquier momento sin la necesidad de procurarla.

Antes de cualquier manutención desconecte la maquina de la red eléctrica.

Proporcione espacio suficiente para evitar caídas peligrosas.

Agua o aceite podrá hacer resbaloso y peligroso el piso. Para evitar accidentes el piso debe estar seco y limpio.

Antes de accionar cualquier comando manual (botones, llaves eléctricas, palancas, etc.) verifique siempre si el comando es el correcto, o en caso de dudas, consulte este Manual. Nunca toque ni accione un comando manual (botones, llaves eléctricas, palancas etc.) por acaso.

Si un trabajo debe ser hecho por dos o más personas, señales de coordinación deben ser dados antes de cada operación. La operación siguiente no debe ser comenzada sin que la respectiva señal sea dada y respondida.

4.1.3 Avisos

En el caso de falta de energía eléctrica, desligue inmediatamente la llave liga / desliga.

Use solamente óleos lubricantes o grasas recomendadas o equivalentes.

11. Lubrication

Lubricate the sliding guides once a week.



ATTENTION

Use only food-grade lubricant.

To properly lubricate the guides, follow the instructions below:

Using a spray bottle or brush with lubricant, lubricate the sliding guide of the product support.

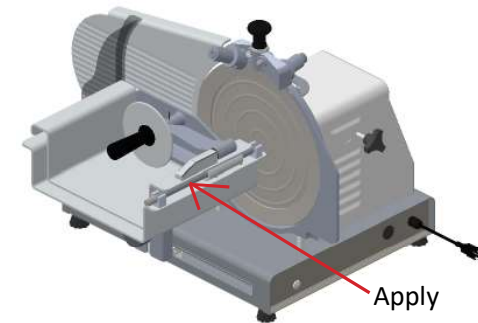

Using a spray bottle or brush with lubricant, lubricate the sliding guide of the product support.

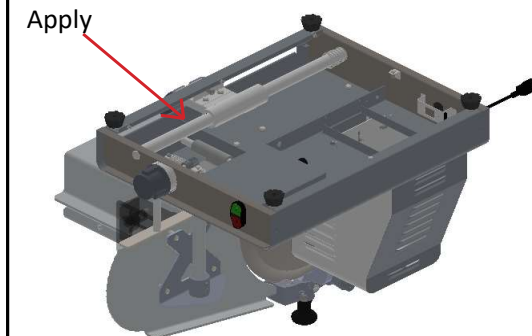

- Spread a small amount of oil on the guides and move the assembly 2 to 3 times.
- After lubrication, wipe away any excess oil.

3.6 Afilado del disco de corte

La cortadora de fiambres incorpora un eficaz sistema de afilado. Este sistema se divide en un afilador de rectificado (artículo 01, fig. 06) y un afilador de acabado (artículo 02, fig. 06).

Para afilar el disco de corte, proceda de la siguiente manera:

- Coloque la mesa de ajuste de corte en la posición CERO;

Figura 06

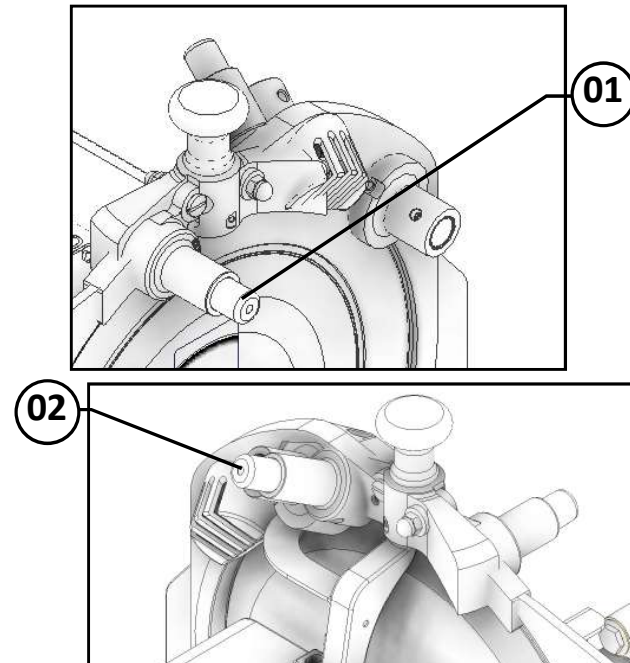

IMPORTANTE
Após feita a afiação do Disco, retorne o Afiador a posição inicial.

3.5 Removiendo el afiador

Afloje la Manipula No.01 (Fig. 09) . Retire el Afilador No. 02 (Fig.10) , tirandolo para arriba

FIGURA 09



FIGURA 10



3.5.1 Retirando el rascador de la chapa

Para retirar el Rascador No.01 (Fig.14) tirelo para arriba. Para colocarlo de vuelta encájelo y empujelo para abajo.

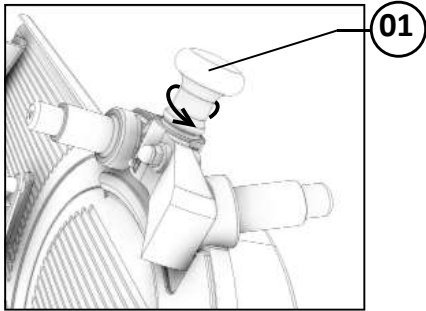
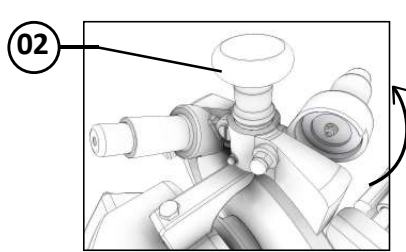
FIGURA 14



INDICE

1. INTRODUCCIÓN	16
1.1 Seguridad	16
1.2 Componentes Principales.....	17
1.3 Características Técnicas	18
2. INSTALACIÓN Y PRÉ – OPERACIÓN	18
2.1 Instalación	18
2.2 Pre Operación.....	19
3. OPERACIÓN	20
3.1 Accionamiento.....	20
3.2 Procedimiento para el uso	20
3.3 Limpieza	20
3.4 Removiendo el protector del disco.....	20
3.5 Removiendo la mesa movable superior y inferior	21
3.5 Removiendo el afiador.....	22
3.5 Retirando el rascador de la chapa	22
4. NOCIONES GENERALES DE SEGURIDAD	24
4.1 Practicas Básicas de Operación	24
4.2 Cuidados y Observaciones Antes de Prender la Maquina.	25
4.3 Inspección de Rutina	25
4.7 Aviso	26
4.4 Operación.....	26
4.5 Después de Terminar el Trabajo	26
4.6 Manutención	26
5 ANÁLISIS Y SOLUCIÓN DE PROBLEMAS	27
5.1 Problemas, Causas y Soluciones	27
6 CONSEJOS GENERALES	29
7. DIAGRAMA ELÉCTRICO	30
SKYFOOD EQUIPMENT LLC - SERVICE	31
SKYFOOD’S LIMITED WARRANTY	31

1. INTRODUCCIÓN

1.1 Seguridad

Cuando usada incorrectamente , la Cortadora de Carne Mod. CF-350 es una maquina potencialmente PELIGROSA . La manutención , la limpieza o otra cualquier actividad de servicio , solamente deben ser hechas por personas debidamente entrenadas , y con la maquina desconectada de la red eléctrica .

Las instrucciones abajo deberán ser seguidas para evitar accidentes :

1.1.1 Desconecte la maquina de la red eléctrica cuando sea deseado retirar cualquier parte removible , para hacer la limpieza , la manutención o otro cualquier servicio.

1.1.2 Nunca usar instrumentos fuera a los que acompañan la maquina para auxiliar en su operación .

1.1.3 Antes de ligar la maquina , verifique si las partes removibles están fijas en sus posiciones .

1.1.4 Nunca use chorros de agua directamente sobre la maquina .

1.1.5 Nunca use ropas con mangas anchas , principalmente en los puños , durante la operación .

1.1.6 Nunca trabaje sin el Protector del Disco No. 08 (Fig. 01) y tampoco lo retire con la maquina conectada a la red eléctrica .

1.1.7 Mantenga las manos lejos de las partes movibles.

1.1.8 Nunca ligue la maquina con las manos , los zapatos o ropas mojadas .

1.1.9 Cuando se haga la instalación de la maquina no sea olvidado de hacer la conexión de tierra. Una buena conexión a la tierra es importante para la seguridad suya y del equipo.



FIGURA 03



FIGURA 04



IMPORTANTE
Al se retirar el Protector del Disco No.02 (Fig.04) , tenga cuidado con el Disco de Corte No.02 (Fig.03) , pues es afilado y puede cortar .

3.5 Removiendo la mesa movable superior y inferior

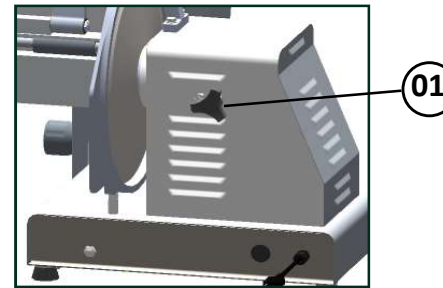
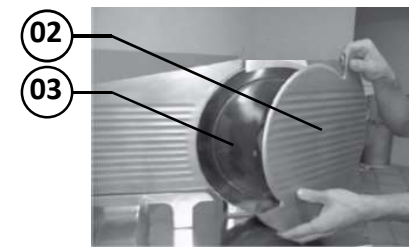
Para retirar la Mesa Movable Superior No.02 (Fig.06) afloje la Manipula del Prendedor No.01 (Fig.05) parcialmente y saque el conjunto entero levantándolo . Para retirar la Mesa Movable Inferior No.04 (Fig.08) afloje la Manipula de la Mesa Movable No.03 (Fig.07) y saquela verticalmente para arriba.

FIGURA 05 (DETALLE A)



FIGURA 06



FIGURA 07



FIGURA 08

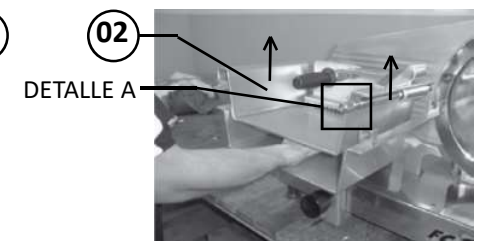
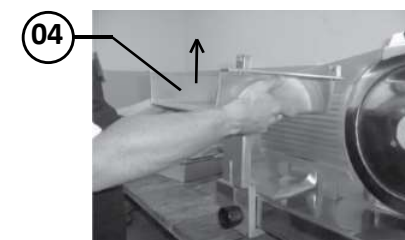

3. OPERACIÓN

3.1 Accionamiento

Se apriete el botón verde Liga/Desliga No. 05 que se encuentra en la lateral izquierda de la Base No.04 (Fig.01).

3.2 Procedimiento para el uso

Levante la Manipula Empujadora No.09 (Fig.01) hasta su posición final. Coloque la carne (sin hueso) sobre la Mesa Movable Superior No.10 (Fig.01), en seguida baje la Manipula Empujadora sobre ella. Utilice la Manipula Reguladora de Corte No.06 (Fig.01) para determinar el espesor deseado de la tajada de carne . La Manipula Reguladora de Corte No.06 (Fig.01) tiene graduación milimétrica (mm).

Ligue la maquina, agarre firmemente la Manipula Empujadora No.09 y mueva la Mesa Movable Superior No.10 (Fig.01) para adelante y para atrás. A cada movimiento para atrás de la Mesa Movable Superior No.10 , empuje la carne contra la Mesa Guía de Corte No.03 (Fig.01) y repita la operación.

IMPORTANTE

Certifíquese antes de usar la maquina , que la Mesa Movable Superior No.10 , y el Protector del Disco No.08(Fig.01) estén bien fijos .

3.3 Limpieza

IMPORTANTE

Nunca proceda a la limpieza con la maquina ligada a la red eléctrica , para hacer la limpieza retire el enchufe de su soquete .

Todas las partes movibles deben ser removidas y limpias . Abajo describimos el procedimiento para la remoción de estas partes.

3.4 Removiendo el protector del disco

Suelte la Manipula No.01 (Fig.03), girándola en el sentido anti-horario y retire el Protector del Disco No.02 como en (Fig.04).

1.2 Componentes Principales

Todos los componentes que incorporan la maquina son construidos con materiales cuidadosamente seleccionados para su función , dentro de los padrones de prueba y de la experiencia de SIEMSEN.

Por ejemplo : Aluminio Anodizado y Acero Inoxidable Pulido.

FIGURA 01

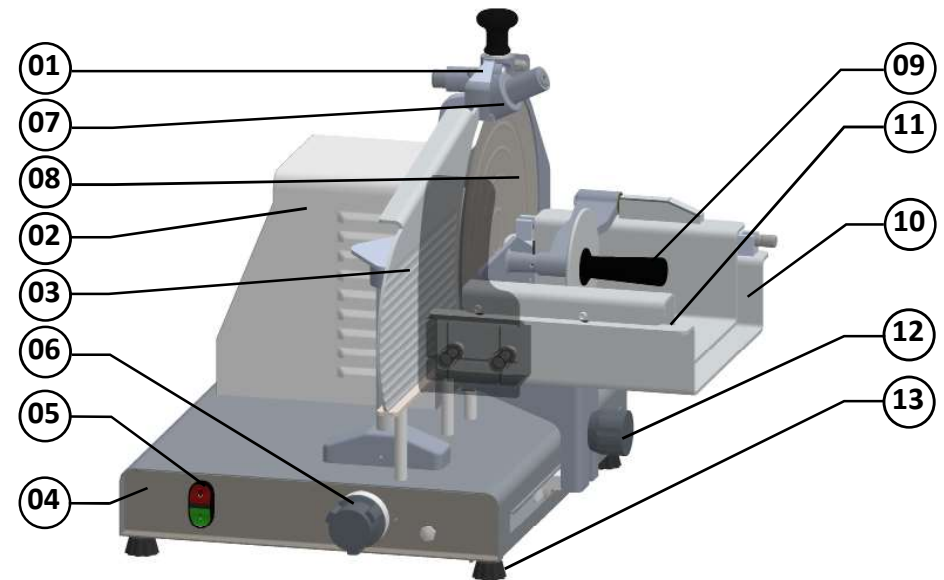

1.Afilador

2.Gabinete

3.Mesa Guía de Corte

4.Base

5.Llave Liga/Desliga

6.Manipula Reguladora de Corte

7.Disco de Corte con 350 mm

8.Protector del Disco

9.Manipula Empujadora

10.Mesa Movable Superior

11.Mesa Movable Inferior

12.Manipula de la Mesa Movable

13.Pies de Goma

1.3 Características Técnicas

TABLA 01

Característica	Unidad	FC-350
Voltaje	V	110/220(*)
Corriente Eléctrica	A	5,6
Frecuencia	Hz	50/60(*)
Potencia	CV	0,5
Consumo	Kw.h	0,38
Altura	mm	525
Ancho	mm	750
Profundidad	mm	760
Peso Neto	kg	49,7
Peso Bruto	kg	65,5
Largura Máxima de Corte	mm	40
Diametro do Disco	mm	350

(*) La frecuencia será única , de acuerdo con la frecuencia del motor .

2. INSTALACIÓN Y PRÉ – OPERACIÓN

2.1 Instalación

La Cortadora de Carne , posee pies de goma antideslizantes , y debe ser instalada sobre una superficie estable de aproximadamente 850 mm de altura (Fig.02) .

Verifique el voltaje de la red eléctrica donde se conectará el enchufe , si es 110 o 220 V. En seguida ajuste el voltaje de la maquina para que sea el mismo del de la red . Para eso, en la parte inferior de la maquina está una Llave Selectora de Voltaje , pongala en el voltaje deseado , la llave esta en la parte inferior de la maquina No. 14 (Fig.01).

El cable de alimentación posee dos clavijas redondas y un hilo de atterramiento - Hilo tierra . Es obligatorio que los tres puntos estén debidamente conectados antes de poner en operación el equipo .

FIGURA 02

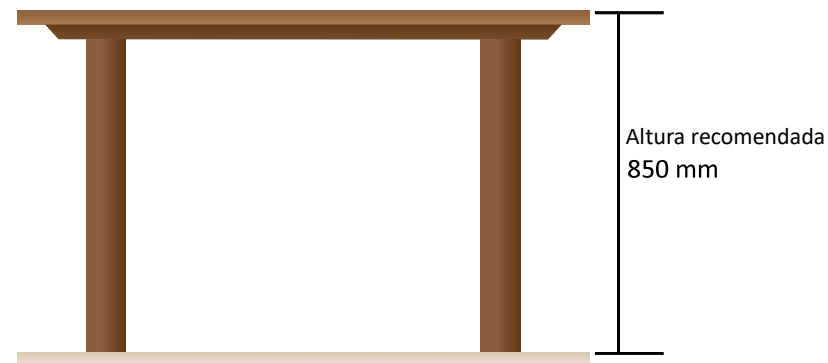

2.2 Pre Operación

Verifique si la Cortadora está firme en su posición . Antes del uso debese lavar con agua y jabón neutro a las partes removibles , enjuague , y las seque antes de reponerlas en la maquina .