

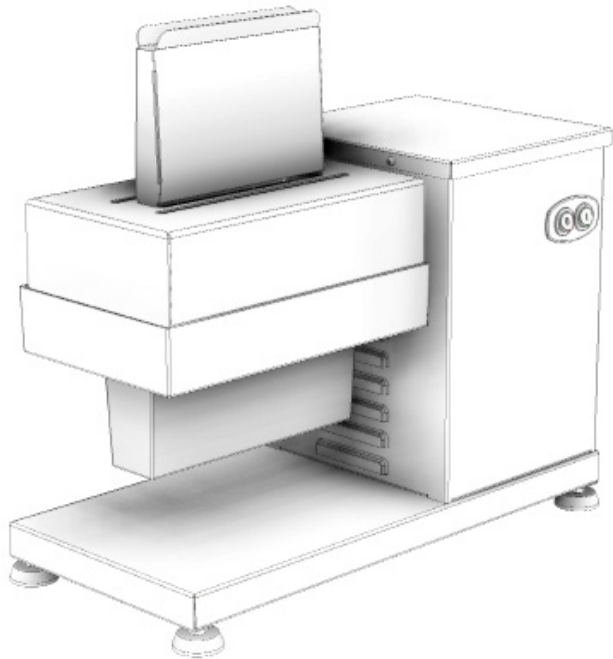

# INSTRUCTION MANUAL



MEAT TENDERIZER

MODEL

**ABS-HD**

# SUMMARY

<b>1. Introduction</b> .....	<b>3</b>
1.1 Safety .....	3
1.2 Main Components .....	5
1.3 Technical Characteristics .....	6
<b>2. Installation and Pre Operation</b> .....	<b>6</b>
2.1 Installation .....	6
2.2 Pre Operation .....	7
<b>3. Operation</b> .....	<b>8</b>
3.1 Starting.....	8
3.2 Operation Procedures.....	8
3.3 To assemble and to Remove the Rolls .....	8
3.4 Safety System .....	13
3.5 Cleaning and Sanitizing .....	14
3.6 Cautions with Stainless Steel .....	15
<b>4. General Safety Practices</b> .....	<b>16</b>
4.1 Basic Operation Practices.....	16
4.2 Safety Procedures and Notes before Switching the Machine ON .....	17
4.3 Routine Inspection.....	18
4.4 Operation .....	18
4.5 After Finishing The Work.....	18
4.6 Maintenance .....	18
4.7 Warning.....	19
<b>5. Analysis and Problems Solving</b> .....	<b>20</b>
5.1 Problem, causes and solutions .....	20
<b>6. Maintenance</b> .....	<b>20</b>
<b>7. Electric Diagram</b> .....	<b>22</b>

# 1. Introduction

## 1.1 Safety

When incorrectly used this equipment is a potentially DANGEROUS machine. Maintenance, cleaning or any other service shall be performed by a duly trained person and with the machine unplugged.

To avoid accidents respect the following instructions:

1.1.1 Read completely these instructions.

1.1.2 To avoid to risk electric shocks and damage to the equipment never use it with wet clothes or shoes and/or standing on wet floors. Do not plunge it into water nor any other liquid, do not spray water directly to the equipment.

1.1.3 When the equipment is in operation the operator shall supervise it, principally when children might be near.

1.1.4 Unplug the equipment when: It is not in use, before to clean it, before to remove or to place some accessory. Before maintenance or any other service.

1.1.5 Do not operate the equipment if the cord or plug are damaged. Do not lean the cord on table edges , nor let them lie on hot surfaces.

1.1.6 When the equipment may have fall, have been damaged any way or simply does not work, take it to Technical Assistance to check.

1.1.7 The use of accessories not recommended by the manufacturer may cause corporal damages.

1.1.8 Keep the hands or any other object away from moving parts while the equipment is in operation.

1.1.9 During operation, never wear loose clothes with wide sleeves principally around the wrists.

1.1.10 Make sure the equipment voltage and the network voltage are the same, and the equipment has been solidly grounded.

1.1.11 Handle with care the Rolls #.04 (Pic.01) because they have sharp edge knives.

1.1.12 Never use instruments to help to place the meat inside the Protection Lid #.05 (Pic.04).

1.1.13 Never remove the Protection Lid # 01 (Pic.01) before to be sure the Rolls #.04 (Pic.01) are totally stopped.

1.1.14 This equipment has been developed for commercial operation, it is used for instance in restaurants, fast foods, hospitals, bakeries, butchers and similar.

It is not recommended to use it:

- For continuous industrial production
- A working ambient having a corrosive or explosive atmosphere, or contaminated with water vapour, dust or gas.

**IMPORTANT**

**For enhanced operator protection, this equipment is provided with a safety system not allowing to be involuntarily switched ON after an eventual energy shortage.**

**IMPORTANT**

**Make sure the cord is in perfect condition for use. If it is not, change it for a new one in accordance with the technical specifications and safety rules.  
The substitution shall be made by a qualified professional, and shall respect the local safety norms.**

**IMPORTANT**

**This equipment must not be used by children or any persons with reduced physical or mental aptness, lack of experience or knowledge, unless they are under supervision or have received from the person responsible for safety, proper instructions on how to use the equipment.**

**IMPORTANT**

**Children shall be watched in order to avoid them to play with the equipment.**

**IMPORTANT**

**In case of emergency take off the plug from its socket.**

**IMPORTANT**

**Never spray water directly on to the equipment.**

## 1.2 Main Components

All components of this equipment were designed and manufactured using carefully selected materials to their proper functions, according to test standards and experience of Skymesen.

**PICTURE 01**

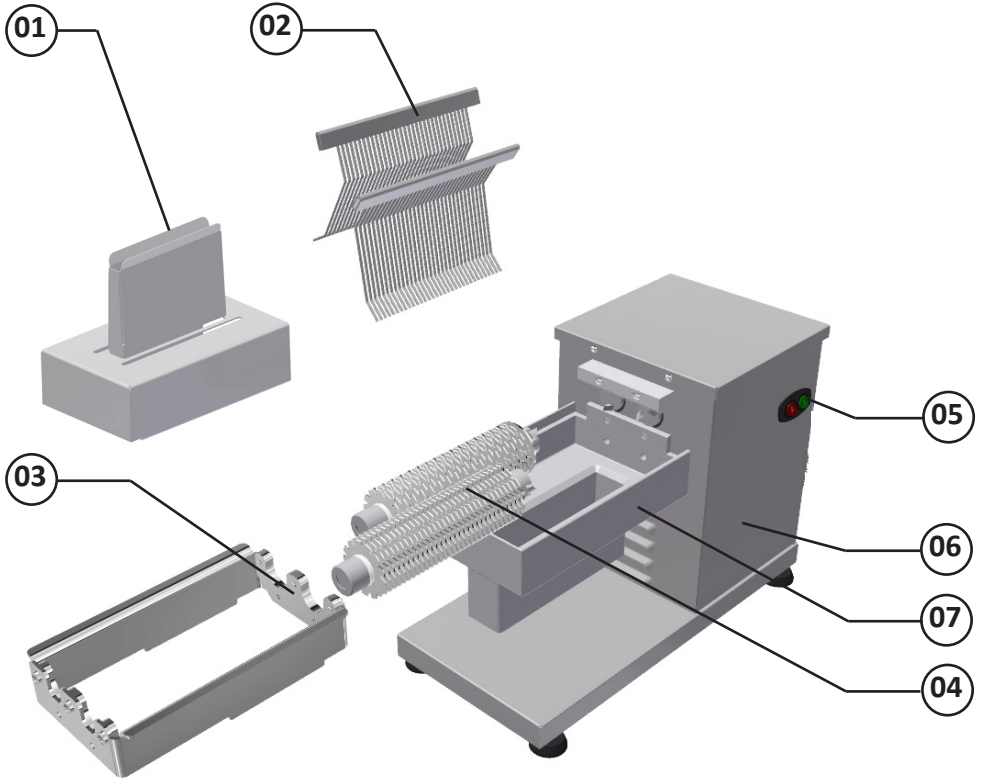

- 01 - Protection Lid
- 02 - Combs
- 03 - Combs Support
- 04- Rolls
- 05 - On/Off Switch
- 06 - Housing
- 07 - Collect Box

### 1.3 Technical Characteristics

**TABLE 01**

CHARACTERISTICS	UNIT	ABS-HD
Voltage	V	110 or 220
Frequency	Hz	50 or 60
Power Rating	W	368
Height	mm	460
Width	mm	260
Depth	mm	535
Net Weight	kg	27
Shipping Weight	kg	28
Dimension of the product to be processed	Width - mm	200
	Thickness - mm	20

## 2. Installation and Pre Operation

### 2.1 Installation

#### 2.1.1 Placing

The equipment must be placed on to a levelled stable surface approximately 850 mm high.

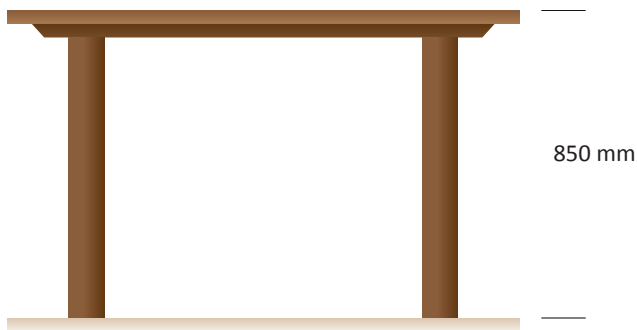

## Recommended area for equipment installation

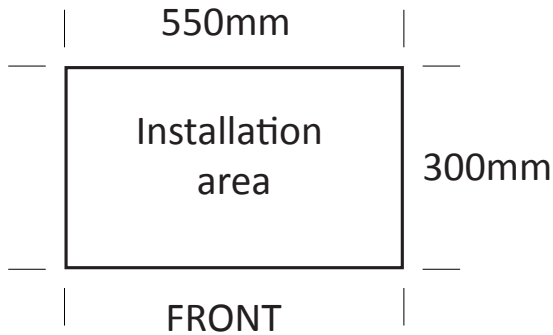

### 2.1.2 Electrical Installation

The equipment has been designed to operate 110 or 220V (50 - 60Hz). When you receive the equipment check the voltage indicated on the cord label.

The power plug has 3 pins, the central one is the ground. All the pins must be properly connected.

#### **IMPORTANT**

**Make sure the network voltage is the same as indicated on the cord label.**

### 2.2 Pre Operation

Before to use the equipment all the parts to be in contact with the product shall be washed with water and neutral soap (see item 3.5 Cleaning).

Make sure the equipment is stable on the working surface.

The Combs (Pic.05) prevent the product to wound up on the Rolls #.04 (Pic.01) and therefore help the product to be expelled.

#### **IMPORTANT**

**Always use the Combs (Picture 05) to process any product.**

## PICTURE 05

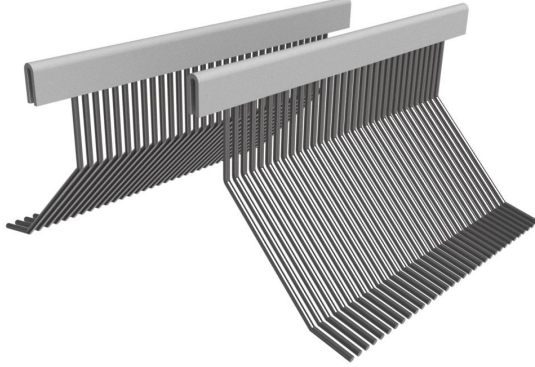

### 3. Operation

#### 3.1 Starting

To start the equipment:

- Plug the equipment on the power point.
- Press the ON/OFF Switch #.05 (Pic.01) to position "I".

#### 3.2 Operation Procedures

##### **ATTENTION**

**Under no circumstances use any instrument to feed the meat inside the Protection Lid # 01 (Pic.01).**

The meat tenderizers are machine working at LOW ROTATION.

Simple to be used they, however, must call the operator total attention to avoid whatever accidents might occur.

Place the meat inside the Protection Lid opening, and let it fall freely inside the machine. See picture 06.

#### 3.3 To assemble and to Remove the Rolls

##### **IMPORTANT**

**Unplug the machine any time you have to take away any of the removable part. Make sure the rolls # 04 (Pic 01) are totally still before to lift the Protection Lid # 01 (Pic.01).**



**PICTURE 04**

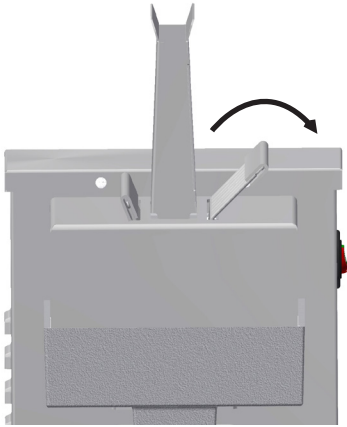

**PICTURE 05**

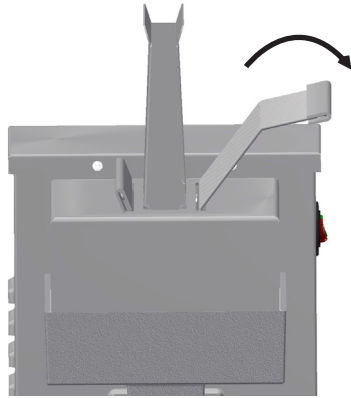

**ATTENTION**

**Remove a comb at a time. Always do this operation with protection cover mounted on the unit as illustrated in Pictures 04 and 05.**

-Remove The protective cover No. 01 (Pic. 01) pulling it back and up as indicated by the arrow direction of Pic. 06.

**PICTURE 06**

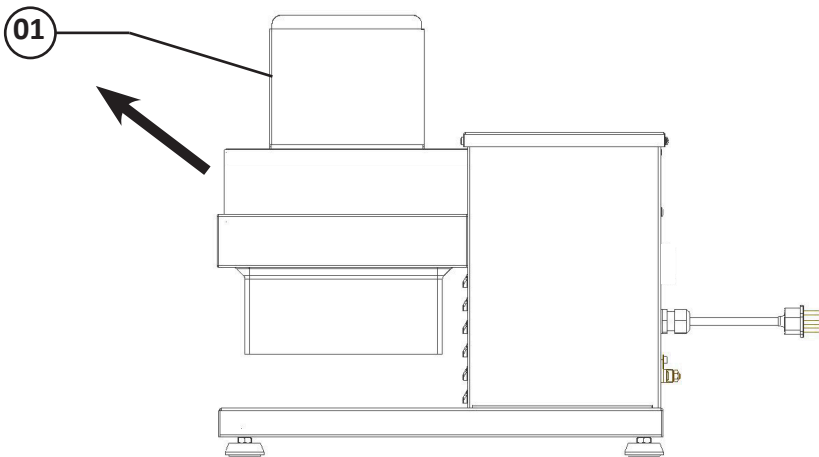

-Place the Protective Cover No. 02 (Pic. 07) with the rollers on a table.

- Lift the front Rollers of Support No. 01 (Pic. 07) until the rolls of support lock disengage the existing plug-in protection cover No. 02 (Pic. 07), and pull it forward until it is totally out of the protective cap No. 02 (Pic. 07) as shown in Pic. 07.

**PICTURE 07**

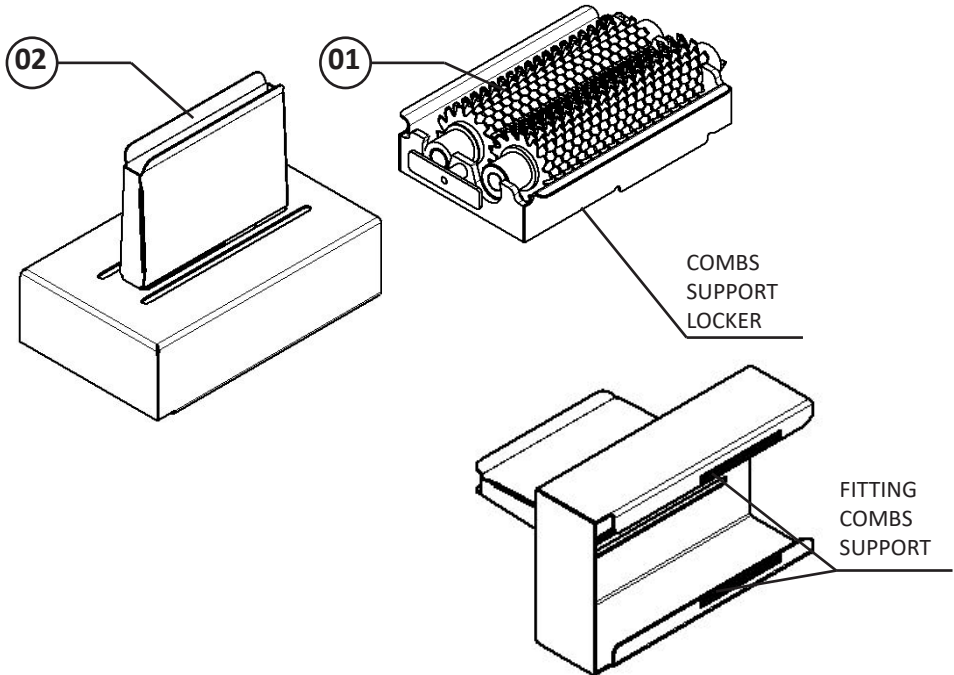

- Remove the rollers picking at their ends as indicated by the arrows and pull them up as Fig 08.

- Remove the two rollers so that the support rollers is completely empty, as shown in Fig 08 and Fig 09.

**PICTURE 08**

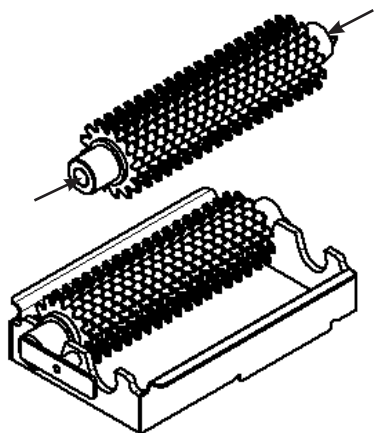

**PICTURE 09**

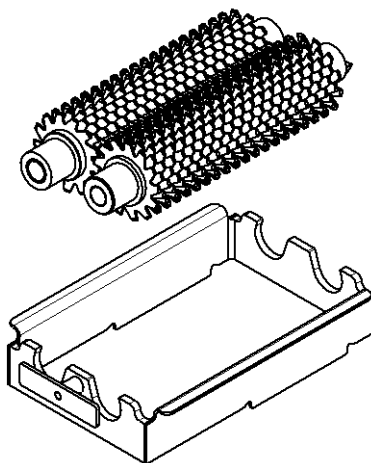

### 3.3.2 Placing the rollers

The rollers must be mounted on the support rollers as described below:

- Place the rolls of support N °01 (Pic. 10) on a table.
- Single roll which has a flange and fit as Pic. 10.
- Each roll has its correct position in the roller support.
- Mount the roll with the flange in position as shown in Pic. 10.
- It is not possible to mount the flange roll in the roller position without the flange.

**PICTURE 10**

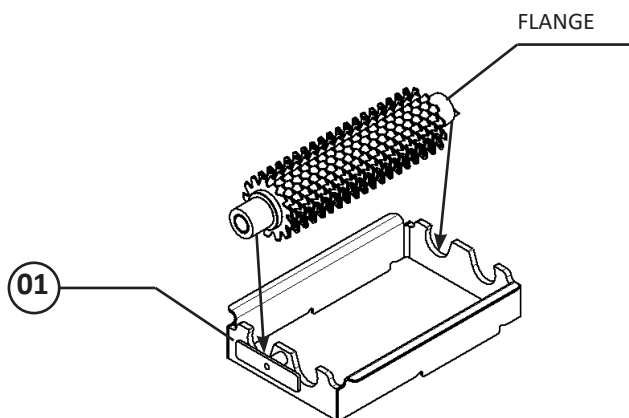

- Mount the second roll in its housing in the combs holder as shown in Pic. 11.

**PICTURE 11**

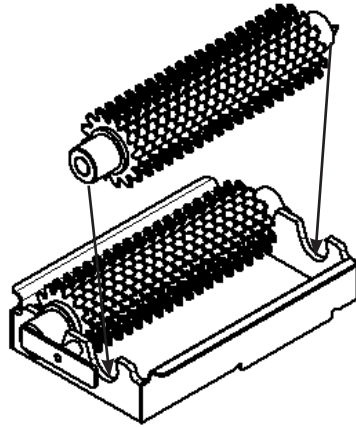

- Note that the teeth on the face of each roller are facing the respective sides.

- Note the correct placement of the rollers, and the No. 1 tooth of the rollers must be inclined to the left side and the teeth of No. 2 rollers must be inclined to the right side as shown in Pic. 12.

**PICTURE 12**

Roll number 01  
inclination direction

Roll number 02  
inclination direction

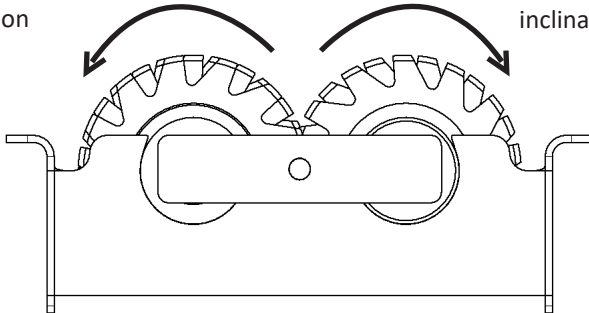

- After correct assembly of the rollers in the roller support, push the support of the rollers inside the protective cover as shown in Pic. 13.

**PICTURE 13**

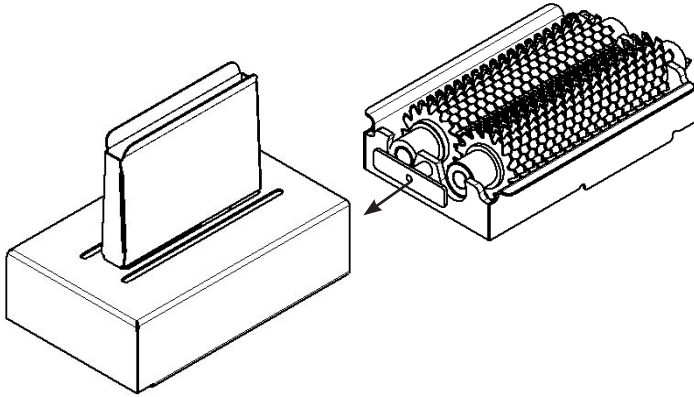

### **3.4 Safety System**

This equipment has a safety system that prevents drive the machine automatically when power is restored after a temporary disconnection. In this case to restart the machine will be necessary to repeat the procedure explained in section 3.1 Starting.

#### **IMPORTANT**

**This machine has a security system to ensure the operator's integrity. Operation of the equipment should be in accordance with item "Operation" of this manual. Other procedures to operate the equipment are unsecured, in this condition the equipment should not be used.**

### 3.5 Cleaning and Sanitizing

**IMPORTANT**

**Never clean the machine when it is connected to the power point, always unplug the machine before cleaning.**

**IMPORTANT**

**Before to remove the Protection Lid # 01 (Pic.01) make sure the Rolls # 02 (Pic.07) are completely stopped.**

The equipment shall be totally cleaned and sanitized:

- Before to be used first time;
- After every day's operation;
- When it has not been used during a long time;
- Before to operate it after a long period unused.

Some parts of the equipment may be removed for cleaning, such as:

- The Protection Lid # 01 (Pic 01);
- The Combs # 02 (Pic 01);
- The Comb Support # 03 (Pic 01);
- The Rolls # 03 (Pic 02);

Read the instructions item 3.3 to place or to remove the Rolls.

Clean all the parts that might get in to contact with the meat with water and neutral soap, wash and dry before to assemble them.

The other parts may be cleaned with a damp cloth.

Never use hard objects as knives, forks or other to clean meat pieces from the Rolls knives. Use a nylon brush.

**IMPORTANT**

**Never spray water directly to the equipment.**

### 3.6 Cautions with Stainless Steel

The Stainless Steel may present rust signs, which ARE ALWAYS CAUSED BY EXTERNAL AGENTS, especially when the cleaning or sanitization is not constant and appropriate.

The Stainless Steel resistance towards corrosion is mainly due to the presence of chrome, which in contact with oxygen allows the formation of a very thin protective coat. This protective coat is formed through the whole surface of the steel, blocking the action of external corrosive agents.

When the protective coat is broken, the corrosion process begins, being possible to avoid it by means of constant and adequate cleaning.

Cleaning must always be done immediately after using the equipment. For such end, use water, neutral soap or detergent, and clean the equipment with a soft cloth or a nylon sponge. Then rinse it with plain running water, and dry immediately with a soft cloth, this way avoiding humidity on surfaces and especially on gaps.

The rinsing and drying processes are extremely important to prevent stains and corrosion from arising.

#### **IMPORTANT**

**Acid solutions, salty solutions, disinfectants and some sterilizing solutions (hypochlorites, tetravalent ammonia salts, iodine compounds, nitric acid and others), must be AVOIDED, once it cannot remain for long in contact with the stainless steel.**

These substances attack the stainless steel due to the CHLORINE on its composition, causing corrosion spots (pitting).

Even detergents used in domestic cleaning must not remain in contact with the stainless steel longer than the necessary, being mandatory to remove it with plain water and then dry the surface completely.

Use of abrasives:

Sponges or steel wool and carbon steel brushes, besides scratching the surface and compromising the stainless steel protection, leave particles that rust and react contaminating the stainless steel. That is why such products must not be used for cleaning and sanitization. Scrapings made with sharp instruments or similar must also be avoided.

Main substances that cause stainless steel corrosion:

Dust, grease, acid solutions such as vinegar, fruit juices, etc., saltern solutions (brine), blood, detergents (except for the neutral ones), common steel particles, residue of sponges or common steel wool, and also other abrasives.

## 4. General Safety Practices

### IMPORTANT

**If any recommendation is not applicable to your equipment, please ignore it.**

The following safety instructions are addressed to both the operator of the machine as well as the person in charge of maintenance.

The machine has to be delivered only in perfect conditions of use by the Distributor to the user. The user shall operate the machine only after being well acquainted with the safety procedures described in the present manual. **READ THIS MANUAL WITH ATTENTION.**

### 4.1 Basic Operation Practices

#### 4.1.1 Dangerous parts

Some areas of the electric device have parts that are connected or have parts connected to high voltage. These parts when touched may cause severe electrical shocks or even be fatal.

Never touch commands such as buttons, turning keys and knobs with wet hands, wearing wet clothes and/or wet shoes. By not following these instructions operator could be exposed to severe electrical shocks or even to a lethal situation.

#### 4.1.2 Warnings

The operator has to be well familiar with the position of ON/OFF Switch to make sure the Switch is easy to be reached when necessary.

Before any kind of maintenance, physically remove plug from the socket. Provide space for a comfortable operation thus avoiding accidents. Water or oil spilled on the floor will turn it slippery and dangerous. Make sure the floor is clean and dry.

Never use a manual command (switch, buttons, lever) unadvisedly. If any work is to be made by two or more persons, coordination signs will have to be given for each operation step. Every step of the operation shall be taken only if a sign has been made and responded.

#### 4.1.3 Precautions



In case of power shortage, immediately switch the machine off

- Use recommended or equivalent lubricants, oils or greases.
- Avoid mechanical shocks, once they may cause damages or bad functioning.
- Avoid water and dust entrance on the mechanical e electrical components of the machine.
- Do NOT change the standard characteristics of the machine.
- DO NOT remove, tear off or maculate any labels stuck on the machine. If any labels have been removed or are no longer legible, contact your nearest dealer for replacement.

## 4.2 Safety Procedures and Notes before Switching the Machine ON

### **IMPORTANT**

**Carefully read ALL INSTRUCTIONS of this manual before turning the machine ON. Be sure to well understand all the information contained in this manual. If you have any question contact your supervisor or your nearest Dealer.**

#### 4.2.1 Danger

An electric cable or electric wire with damaged jacket or bad insulation might cause electrical shocks as well as electrical leak. Before use, check the conditions of all wires and cables.

#### 4.2.2 Advices

Be sure ALL INSTRUCTIONS in this manual have been thoroughly understood. Every function and operational procedure has to be thoroughly clear to the operator.

Any manual command (switch, button or lever) shall be given only after being sure it is the correct one.

#### 4.2.3 Precautions

The electric cable has to be compatible with the power required by the machine.

Cables touching the floor or close to the machine need to be protected against short circuits.

## **4.3 Routine Inspection**

### **4.3.1 Advice**

When checking the tension of the belts or chains, DO NOT introduce your fingers between the belts and the pulleys and nor between the chain and the gears.

### **4.3.2 Precautions**

Check if motors and sliding or turning parts of the machine produce abnormal noises.

Check the tension of the belts and chains and replace the set when belt or chain show signs of being worn out.

When checking tensions of belts or chain DO NOT introduce your fingers between belts and pulleys, nor between the chains and gears.

Check protections and safety devices to make sure they are working properly.

## **4.4 Operation**

### **4.4.1 Advice**

Be sure your hair is not loose in order to avoid getting caught by turning parts which could lead to a serious accident. Tie your hair up well and/or cover your head with a scarf.

The operation performed by not trained or skilled personnel shall be forbidden.

NEVER operate machine without any original safety devices under perfect conditions.

## **4.5 After Finishing The Work**

### **4.5.1 Precautions**

Always TURN THE MACHINE OFF by removing the plug from the socket before cleaning the machine.

Never clean the machine unless it has come to a complete stop.

Put all components back to their functional positions before turning it ON again. DO NOT place your fingers in between belts and pulleys nor chains and gears.

## **4.6 Maintenance**

#### 4.6.1 Dangers

Any maintenance with the machine in working situation is dangerous.

TURN IT OFF BY PULLING THE PLUG OFF THE SOCKET DURING MAINTENANCE.

#### **IMPORTANT**

**Always remove the plug from the socket in any emergency situation.**

#### 4.7 Warning

Electrical or mechanical maintenance has to be undertaken by qualified personnel.

The person in charge of maintenance has to be sure that the machine is under TOTAL SAFETY conditions when working.

## 5. Analysis and Problems Solving

### 5.1 Problem, causes and solutions

The equipment has been designed to operate with the need of minimum maintenance but the natural wearing caused by longer use of the equipment may occasionally cause some malfunctions.

If such problem occurs with your equipment, refer to Table 02 in which the most common situations are listed with recommended solutions.

## 6. Maintenance

Maintenance should be considered a set of procedures aimed at keeping equipment in top operating conditions, providing greater longevity and security.

\* Cleaning - Cleaning Check item 3.3 of this manual.

\* Wiring - Check all cables for impairment and all contacts (terminals) Electric for tightness and corrosion.

\* Contacts - On / off switch, emergency button, reset button, electronics, etc. Check the equipment so that all components are working properly and that the device operation is normal.

\* Installation - Check the installation of your equipment as per item 2.1 Installation of this manual.

\* Product Lifecycle - 2 years, for a normal shift.

1 - Items to check and perform monthly:

- Check the electrical installation;
- Measure the mains voltage;
- Measure the operating current and compare with the nominal;
- Check tightness of all electrical terminals of the device to avoid possible bad contacts;
- Check any slack of the electric motor shaft;
- Check the wiring and electrical cables for signs of overheating, poor insulation or mechanical breakdown.

2 - Check Items and run every 3 months:

- Check electrical components such as on / off switch, emergency button, reset button and electronic circuit as the signs of overheating, poor insulation or mechanical breakdown.
- Check any slack in the bearings and bearings.
- Check seals, o-rings, v'rings rings and other seals systems.

**TABLE 02**

<b>PROBLEMS</b>	<b>CAUSES</b>	<b>SOLUTIONS</b>
- The machine does not switch on.	- Lack of electric power. - Problems with electrical circuit.	- Check if plug is connected to its socket, or if there is electric shortage. - Call Technical assistance.
- Smoke or burnt smell.	- Problems with the electrical circuits.	- Call Technical assistance.
- The equipment switches ON.	- Problem with the motor.	- Call Technical assistance.
- Damaged cord.	- Failure during product transportation.	- Call Technical assistance.
- Unusual noises.	- Damaged bearings.	- Call Technical assistance.

## 7. Electric Diagram

### ELECTRICAL NETWORK

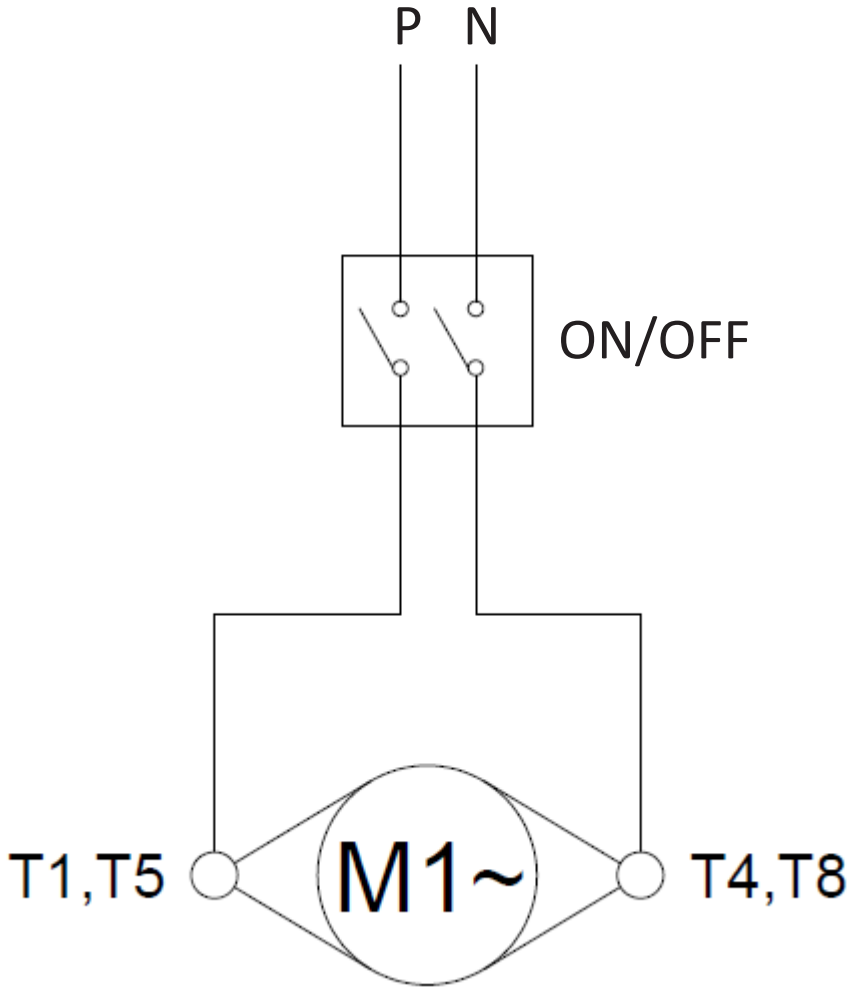



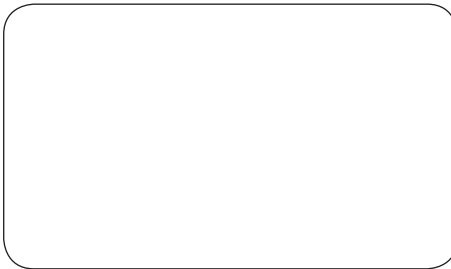

Metalúrgica Skymesen Ltda.  
Rodovia Ivo Silveira 9525  
Volta Grande  
88355-202 Brusque/SC/Brasil  
[www.skymesen.com](http://www.skymesen.com) - Fone: +55 47 3211 6000  
CNPJ: 82.983.032/0001-19 - IE 250.064.537

65746.8 - INGLÊS

Data de Revisão: 12/09/2019

- 
- Besides this equipment, a complete range of other products are manufactured, consult our dealers.
  - Due to the constant improvements introduced to our equipments, the information contained in the present Instruction Manual may be modified without previous notice.

**WWW.SKYMSEN.COM**